

Plena Feedback Suppressor



Security Systems

en | Installation and Operating Manual
LBB 1968

BOSCH

Important safeguards

- 1 Read instructions - All the safety instructions for use should be read before the system is operated.
- 2 Retain instructions - The safety instructions and instructions for use should be retained for future reference.
- 3 Heed warnings - All warnings on the unit and in the operating instructions should be adhered to.
- 4 Follow instructions - All operating instructions and instructions for use should be followed.
- 5 Cleaning - Unplug system units from the mains outlet before cleaning. Do not use liquid cleaners or aerosol cleaners. Use a damp cloth for cleaning.
- 6 Attachments - Do not use attachments not recommended by the product manufacturer as they may cause hazards.
- 7 Water and Moisture - Do not use this unit near water, for example near a bathtub, washbowl, kitchen sink, or laundry basket, in a wet basement, near a swimming pool, in an unprotected outdoor installation or any area which is classified as a wet location.
- 8 Accessories - Do not place this unit on an unstable stand, tripod, bracket or mount. This unit may fall, causing serious injury to a person and serious damage to the unit. Use only a stand, tripod, bracket or mount recommended by the manufacturer, or sold with the product. Any mounting of the unit should follow the manufacturer's instructions, and should use a mounting accessory recommended by the manufacturer. An appliance and cart combination should be moved with care. Quick stops, excessive force, and uneven surfaces may cause the appliance and cart combination to overturn.
- 9 Ventilation - Openings in the enclosure, if any, are provided for ventilation and to ensure reliable operation of the unit and to protect it from overheating. These openings must not be blocked or covered. The unit should not be placed in a built-in installation unless proper ventilation is provided or the manufacturer's instructions have been adhered to.
- 10 Power sources - Units should be operated only from the type of power source indicated on the marking label. If you are not sure of the type of power supply you plan to use, consult your appliance dealer or local power company. For units intended to operate from battery power, or other sources, refer to the "Installation and User Instructions".
- 11 Grounding or polarisation - This unit may be equipped with a polarised alternating current line plug (a plug having one blade wider than the other). This plug will fit into the power outlet only one way. This is a safety feature. If you are unable to insert the plug fully into the outlet, try reversing the plug. If the plug still fails to fit, contact your electrician to replace your obsolete outlet. Do not defeat the safety purpose of the polarised plug. Alternatively, this unit may be equipped with a 3-wire grounding type plug having a third (grounding) pin. This plug will only fit into a grounding-type power outlet. This is a safety feature. If you are unable to insert the plug into the outlet, contact your electrician to replace your obsolete outlet. Do not defeat the safety purpose of the grounding-type plug.
- 12 Power-Cord Protection - Power supply cords should be routed so that they are not likely to be walked on or pinched by items placed upon or against them, paying particular attention to cords and plugs, convenience receptacles, and the point where they exit from the appliance.
- 13 Overloading - Do not overload outlets and extension cords as this can result in a risk of fire or electrical shock.
- 14 Object and Liquid Entry - Never push objects of any kind into this unit through openings as they may touch dangerous voltage points or short-out parts that could result in a fire or electric shock. Never spill liquid of any kind on the unit.
- 15 Servicing - Do not attempt to service this unit yourself as opening or removing covers may expose to dangerous voltage or other hazards. Refer all servicing to qualified service personnel.
- 16 Damage Requiring Service - Unplug the unit from the outlet and refer servicing to qualified service personnel under the following conditions:
 - When the power-supply cord or plug is damaged.
 - If liquid has been spilled, or objects have fallen into the unit.
 - If the unit has been exposed to rain or water.
 - If the unit does not operate normally by following the instructions for use. Adjust only those controls that are covered by the instructions for use, as an improper adjustment of other controls may result in damage and will often require extensive work by a qualified technician to restore the units to their normal operation.
 - If the unit has been dropped or the unit has been damaged.
 - When the unit exhibits a distinct change in performance; this indicates a need for service.
- 17 Replacement Parts - When replacement parts are required be sure the service technician has used replacement parts specified by the manufacturer or parts which have the same characteristics as the original part. Unauthorised substitutions may result in fire, electric shock or other hazards.
- 18 Safety Check - Upon completion of any service or repairs to the units, ask the service technician to perform safety checks to determine that the unit is in proper operating condition.
- 19 Lightning - For added protection of the units during a lightning storm, or when it is left unattended and unused for long periods of time, unplug it from the wall outlet and disconnect the cable system. This will prevent damage to the unit due to lightning and power-line surges.

About this manual

This manual provides all the information required to install and operate the unit.

Conventions

**Warning**

Follow these instructions to prevent personal injury.

**Caution**

Follow these instructions to prevent damage to the equipment.

**Note**

Read these instructions for tips and other useful information.

Safety precautions

**Warning**

Do not open the unit when it is connected to the mains. The unit contains non-insulated parts, which can cause electric shock.

**Caution**

There are no user-serviceable parts inside the unit. Service must be done by qualified personnel.

Table of contents

Important safeguards.....	3
About this manual	4
Safety precautions.....	4
Table of contents	5
1 About the equipment	7
1.1 Functioning (operating principle)	7
1.2 Controls and indicators (front)	8
1.3 Controls and connections (rear)	9
2 Installation in rack	10
3 External settings and connections	11
3.1 Connecting the inputs and the outputs	11
3.1.1 Announcement set-up	11
3.1.2 Live performance set-up and Conference set-up	12
3.1.3 Presentation set-up and set-up in churches, mosques, houses of worship, etc.	14
3.1.4 Signal level	16
3.2 Setting the options switches	17
3.3 Mains connection	19
4 Operation of the feedback suppressor	20
4.1 Switching ON	20
4.2 Calibration	21
4.3 General recommendations to prevent feedback	21
5 Technical data	22
5.1 Electrical	22
5.2 Performance	22
5.3 Inputs	22
5.4 Outputs	23
5.5 Controls and indicators	23
5.6 Environmental conditions	23
5.7 General	23

1 About the equipment

1.1 Functioning (operating principle)

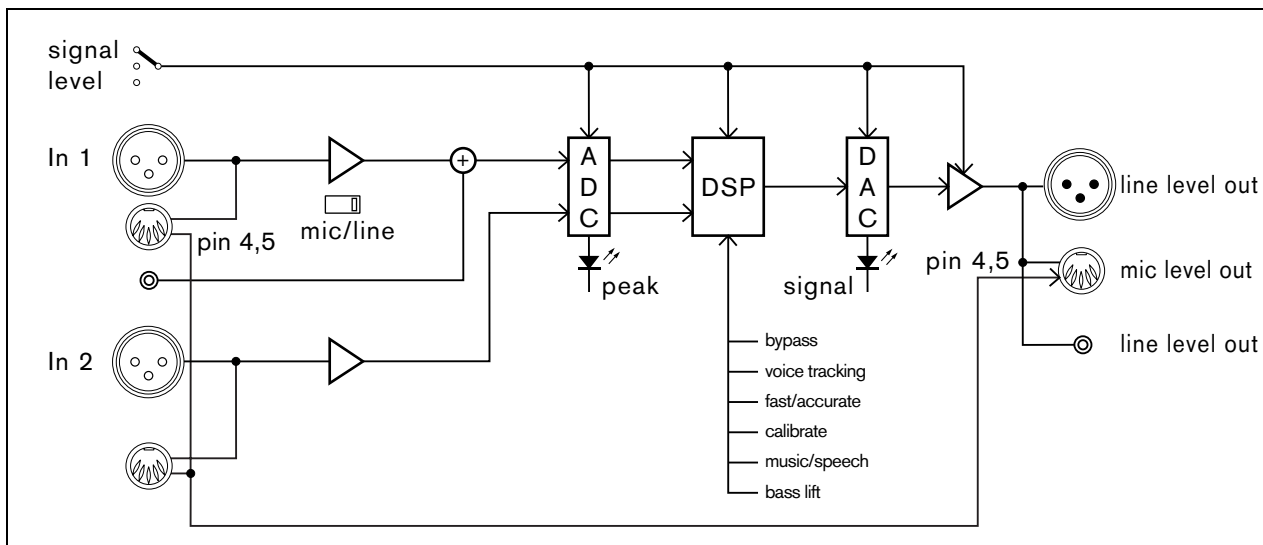

figure 1.1: Block diagram

Feedback suppression

The Plena Feedback Suppressor uses a powerful DSP with a revolutionary patented algorithm to suppress acoustic feedback. It eliminates feedback by actively filtering the room reverb that leads to feedback out of the signal, using an echo cancellation and de-reverberation algorithm. By adding masked (inaudible) noise to the output signal (Music mode) or by just shifting the frequency of the output signal by 5 Hz (Speech mode) the Plena Feedback Suppressor is able to detect the reverb component of the signal and to remove it before feedback occurs, leaving the original signal intact.

Auto Mix function

In addition to its feedback suppression function, the Plena Feedback Suppressor also features a built-in automatic mixer for the two microphone inputs. In many situations two microphones are used to better capture the voice of a moving speaker, like on a rostrum, pulpit or a conference table, but often this increases the risk of acoustic feedback. The automatic mixer of the Plena Feedback Suppressor, however, automatically reduces the gain of the microphone with the lowest signal input and increases the gain of the microphone with the highest signal input. This way it 'tracks' the moving speaker for optimum speech intelligibility, and the maximum feedback margin is maintained by keeping the summed gain constant. Even if the feedback processor is switched to bypass this automatic mixer is still operating.

1.2 Controls and indicators (front)

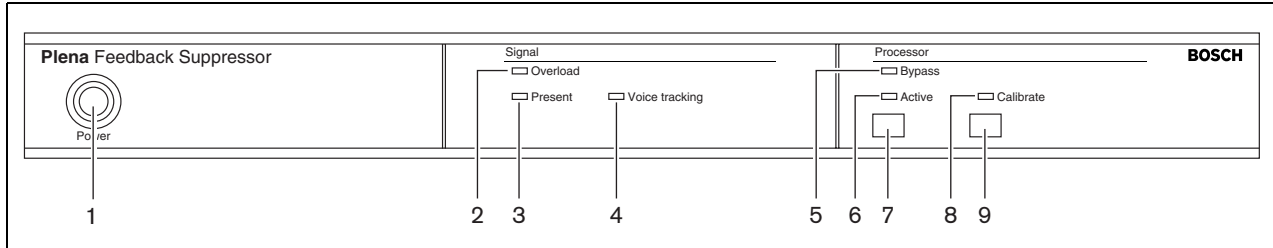

figure 1.2: Controls and indicators (front)

- 1 Power button
- 2 Input signal overload indicator
The LED lights up to indicate a too high input signal. The input sensitivity can be adjusted with the help of the signal level switch on the rear (see §1.3).
- 3 Output signal present indicator
The LED lights up to indicate that the output signal exceeds -40 dBr.
- 4 Auto Mix indicator
The LED lights up to indicate that the Auto Mix function (see §1.1) is active.
- 5 Bypass indicator
The LED lights up to indicate that the feedback suppression function is deactivated.
- 6 Feedback suppression active indicator
The LED lights up to indicate that feedback suppression algorithm is active.
- 7 Bypass switch
- 8 Calibrate indicator
The LED lights up to indicate a fast calibration cycle after pressing the calibrate button (9).
- 9 Calibrate button
Upon pressing the calibrate button, random noise at -6 dBr is generated for a few seconds to allow the feedback suppression algorithm to calibrate quickly.

1.3 Controls and connections (rear)

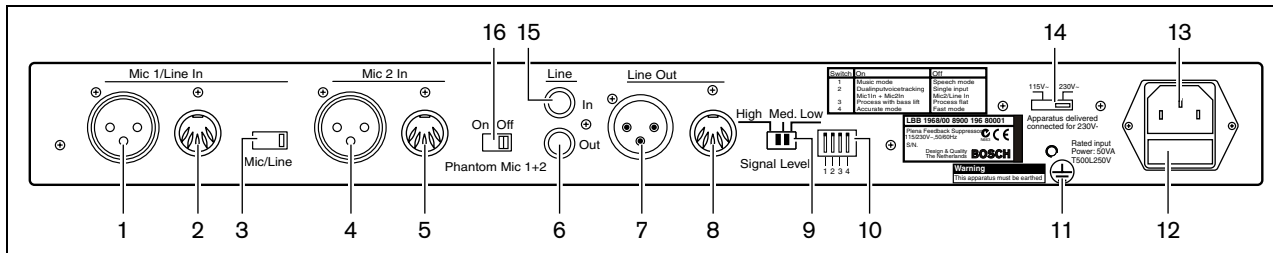

figure 1.3: Controls and connections (rear)

- 1 Microphone 1/Line input (XLR/balanced)
- 2 Microphone 1 input (5-pin DIN/balanced)
- 3 Mic/Line switch
The Mic/Line switch only affects Microphone 1/Line Input (1)
- 4 Microphone 2 input (XLR/balanced)
- 5 Microphone 2 input (5-pin DIN/balanced)
- 6 Line out (Cinch/unbalanced)
- 7 Line out (XLR/balanced)
- 8 Microphone level out (5-pin DIN/balanced). For connection to Plena Amplifiers only (see §3.1)
- 9 Signal level switch (see §3.1)
- 10 Options switches (see §3.2)
- 11 Earth connection screw
- 12 Mains fuse (T500 L 250V)
- 13 Mains connector (3-pole)
- 14 Mains voltage selection switch
- 15 Line in (Cinch/unbalanced)
- 16 Phantom power switch (microphone 1 and 2)
Switch that enables and disables phantom power on Microphone 1/Line input (1 and 2) and Microphone 2 input (4 and 5). When the line input is selected with the help of the Mic/Line switch (3), phantom power is disabled for this input.

2 Installation in rack

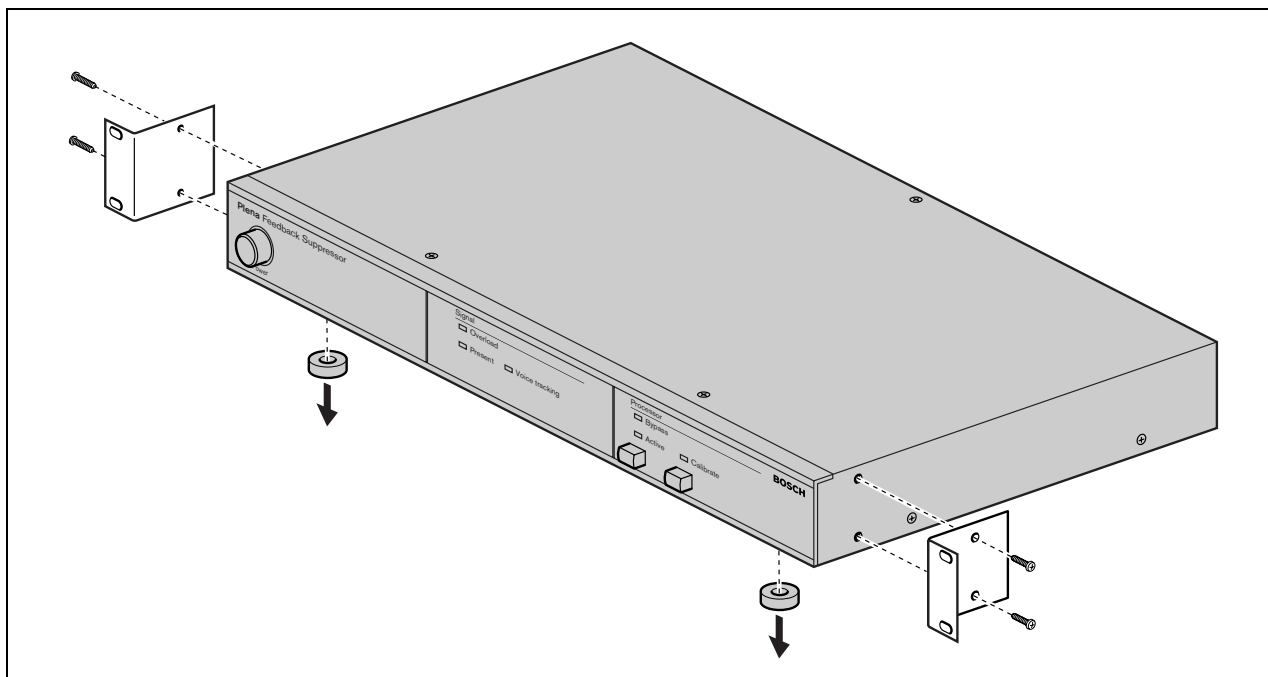

figure 2.1: Installation in rack

The feedback suppressor is delivered for tabletop use, but you can mount it in a 19" rack using the brackets supplied with the unit. In case of rack mounting, you must:

- Remove the 4 feet from the bottom of the unit. Without the feet, the unit is 1U high.
- Ensure that the ambient temperature of the unit in the rack does not exceed 55 °C.

3 External settings and connections

3.1 Connecting the inputs and the outputs

Figures 3.1 through 3.5 show some different configuration set-ups.

3.1.1 Announcement set-up

See fig. 3.1.

The Plena Feedback Suppressor is provided with two balanced DIN-inputs (2 and 5) to connect one or two LBB1950 call stations or LBB1949 gooseneck microphones. The signal inputs are parallel to the balanced XLR-inputs (1 and 4), and the priority contacts are looped through to pins 4 and 5 of the balanced DIN-output (8). The output level on the DIN-output (8) is optimized for the priority microphone input level of the Plena Mixer Amplifier range.

- Set the Mic/Line switch (3) to 'Mic'.
- Enable the phantom power supply with the phantom power switch (16).
- If only one call station is used, connect it to the Microphone 1 input (2).

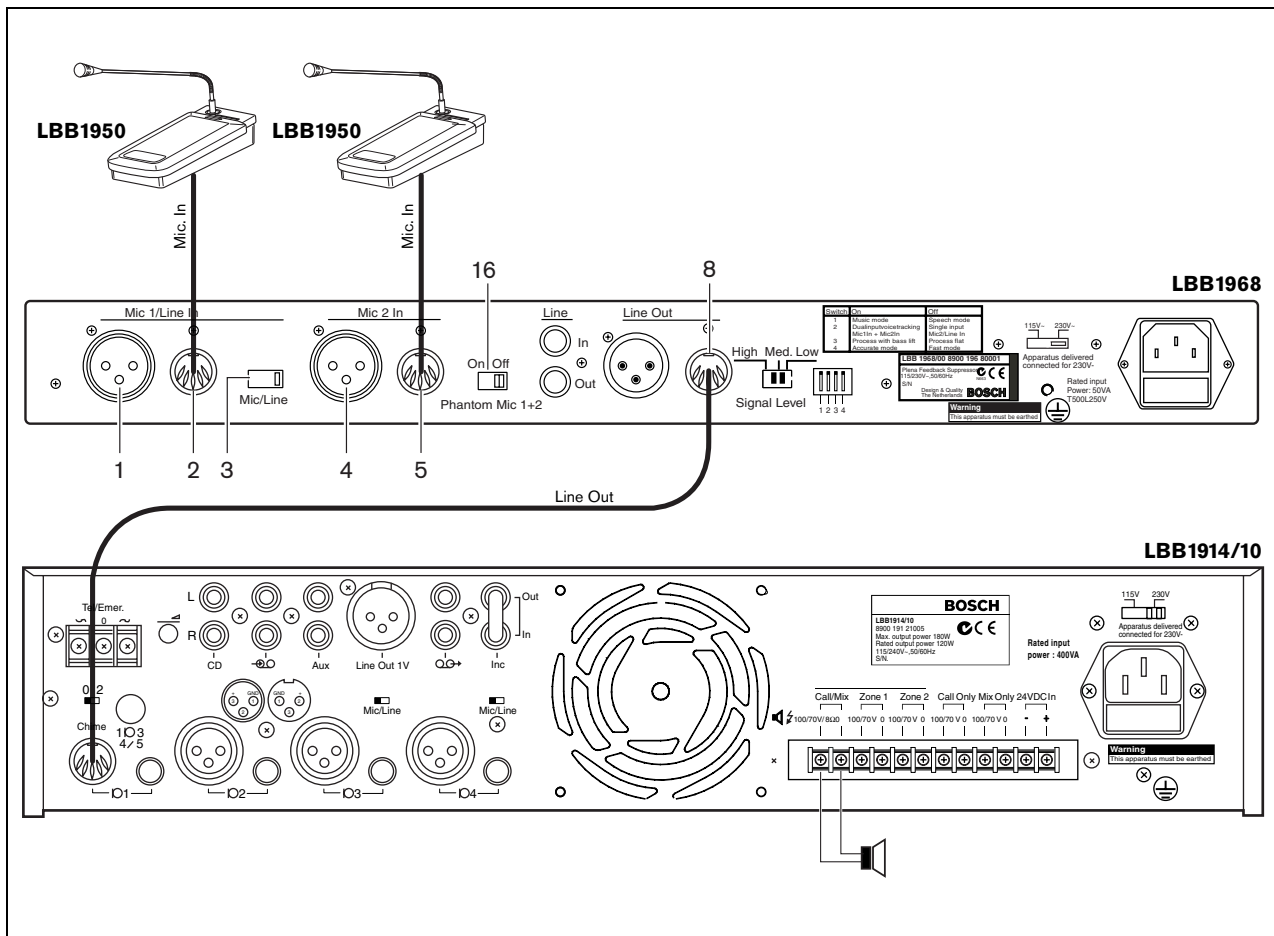

figure 3.1: Announcement set-up

3.1.2 Live performance set-up and Conference set-up

See fig. 3.2 and fig. 3.3, respectively.

The Plena Feedback Suppressor is provided with one balanced XLR-line input (1) and one unbalanced line input (15), e.g. to connect a line level source such as an SR-mixer or a DCN Central Control Unit (please refer to the Operation Manual of your DCN System).

To connect any unit that accepts standard line signals, the unit is provided with one balanced XLR-line output (7) and one unbalanced line output (6).

- Set the Mic/Line switch (3) to 'Line' to use the balanced line input (1). In this case the phantom power switch (16) has no function.

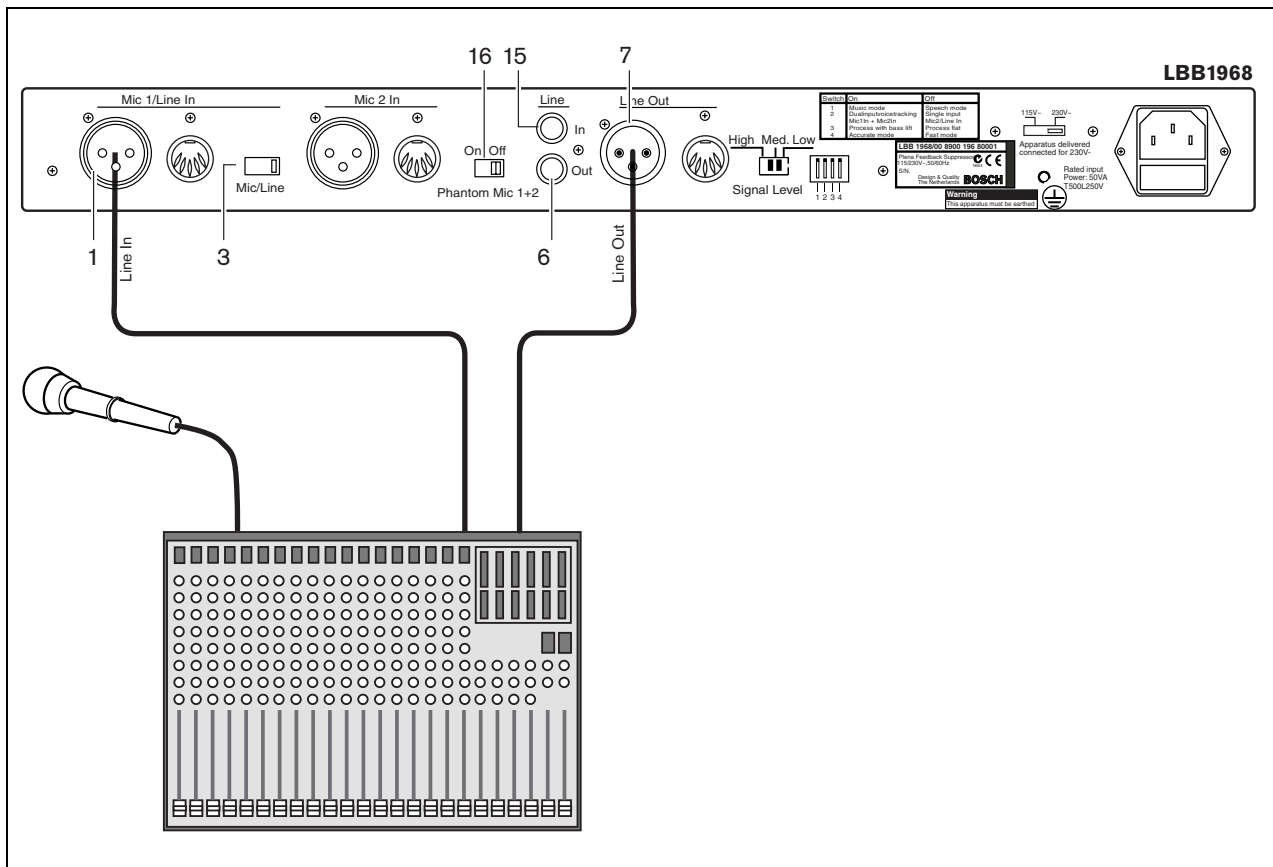

figure 3.2: Live performance set-up

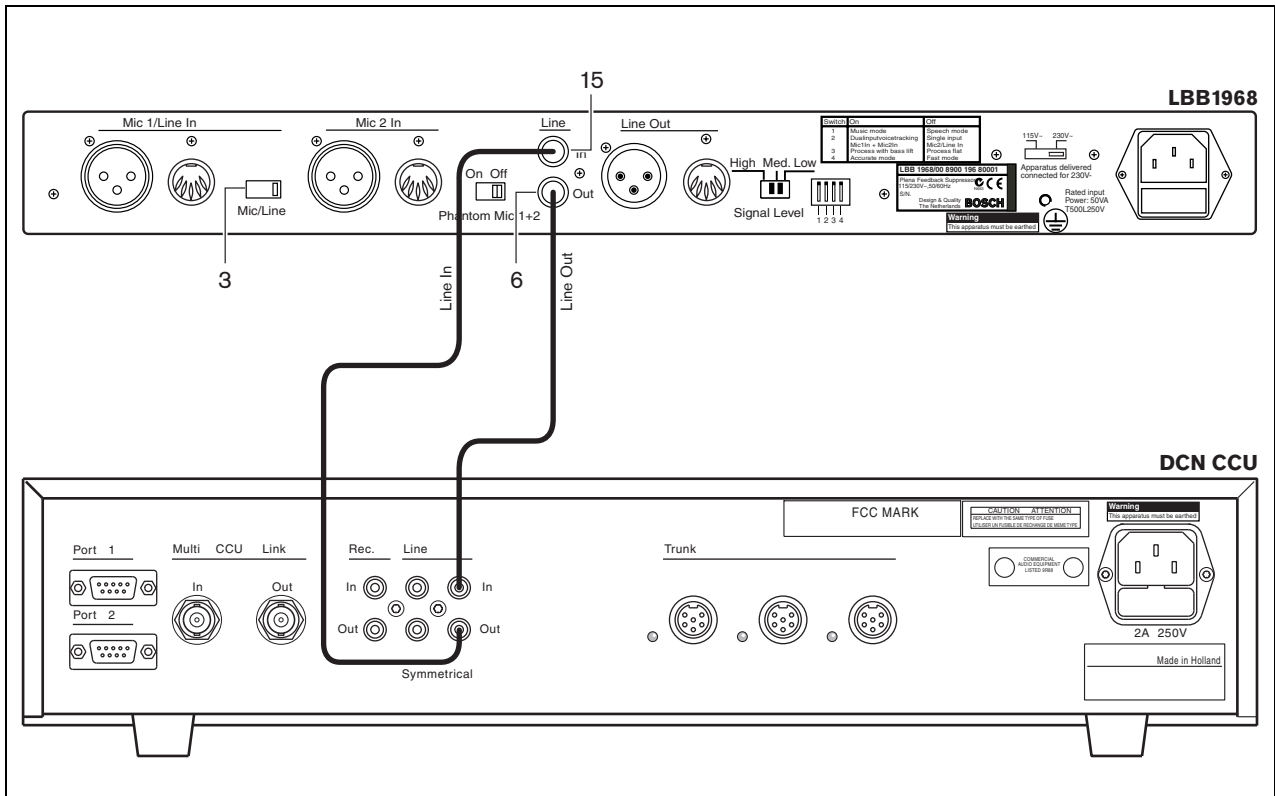

figure 3.3: Conference set-up

3.1.3 Presentation set-up and set-up in churches, mosques, houses of worship, etc.

See fig. 3.4 and fig. 3.5, respectively.

The Plena Feedback Suppressor is provided with two balanced XLR-inputs (1 and 4), e.g. to connect one or two microphones.

- Set the Mic/Line switch (3) to 'Mic'.
- Enable the phantom power supply with the phantom power switch (16).
- If only one microphone is used, connect it to the Microphone 1/Line input (1).

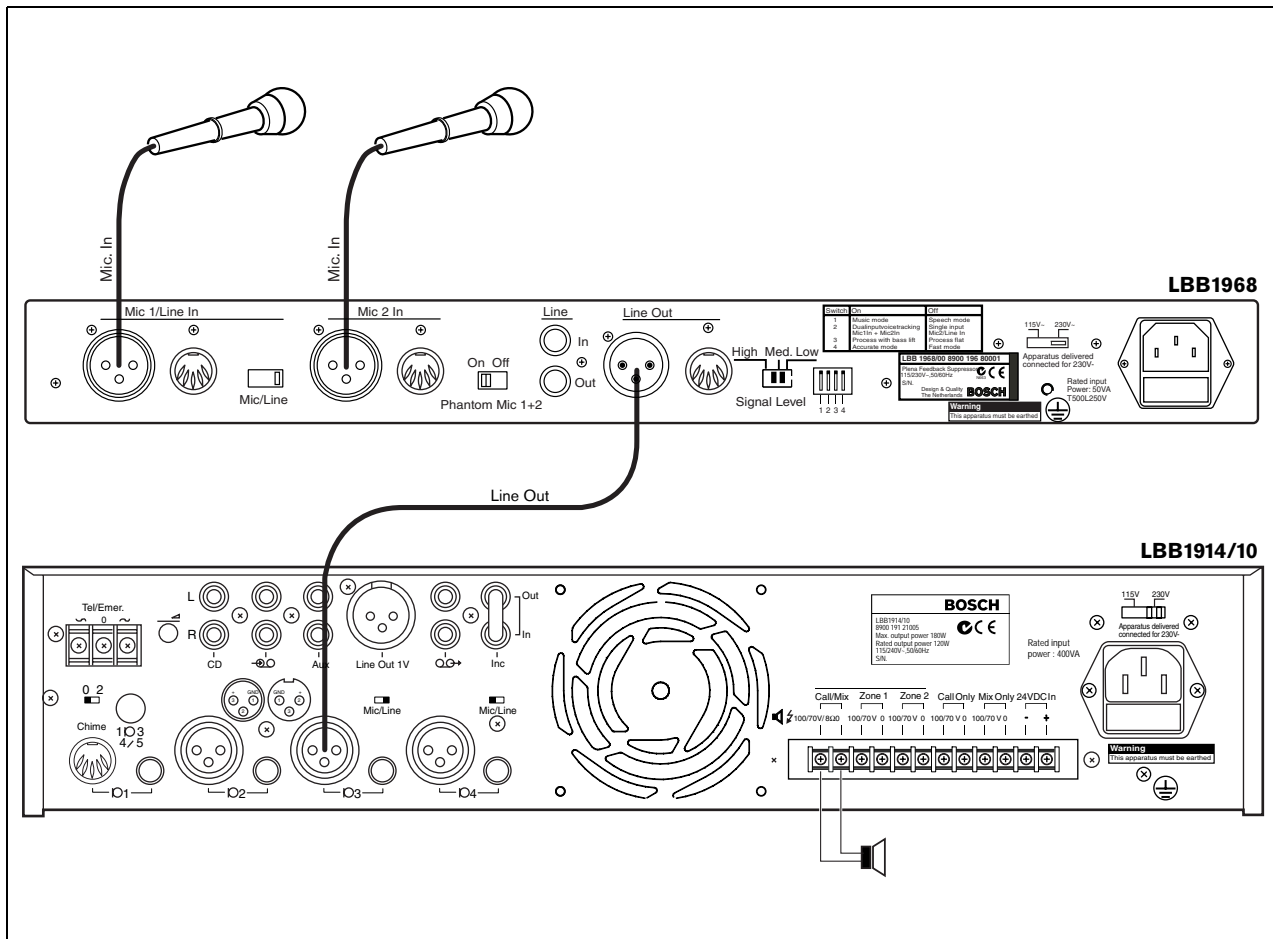

figure 3.4: Presentation set-up

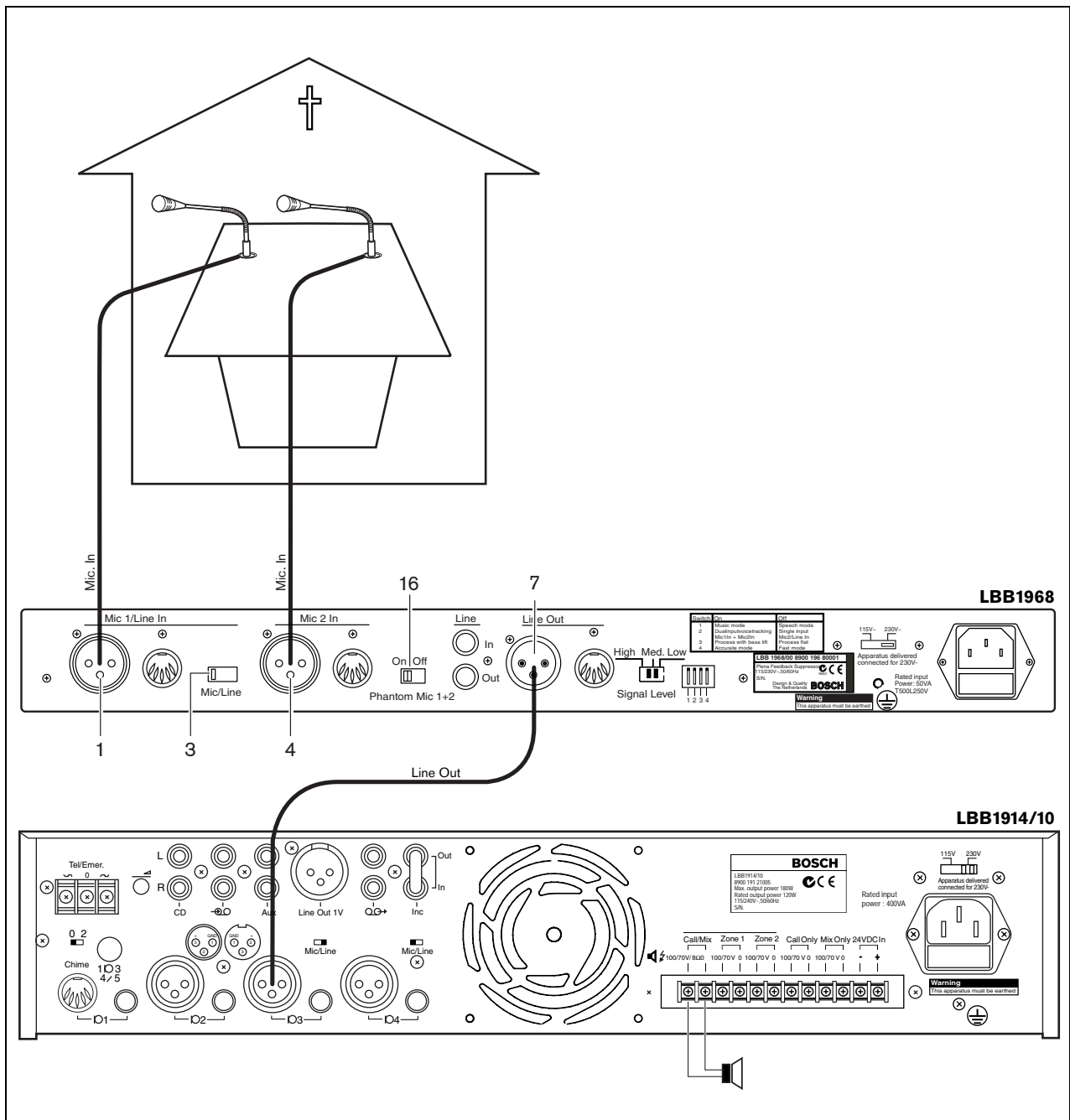

figure 3.5: Set-up in churches, mosques, houses of worship, etc.

3.1.4 Signal level

- Set the signal level switch (9) to the appropriate position in order to optimize the signal-to-noise ratio and to prevent overload. See the tables below.

table 3.1: Line in

	Low	Med	High
Input level	-12 dBV	0 dBV	+12 dBV
Output level	-12 dBV	0 dBV	+12 dBV

table 3.2: Mic in

	Low	Med	High
Input level	-42 dBV	-30 dBV	-18 dBV
Output level	0 dBV	0 dBV	0 dBV

3.2 Setting the options switches

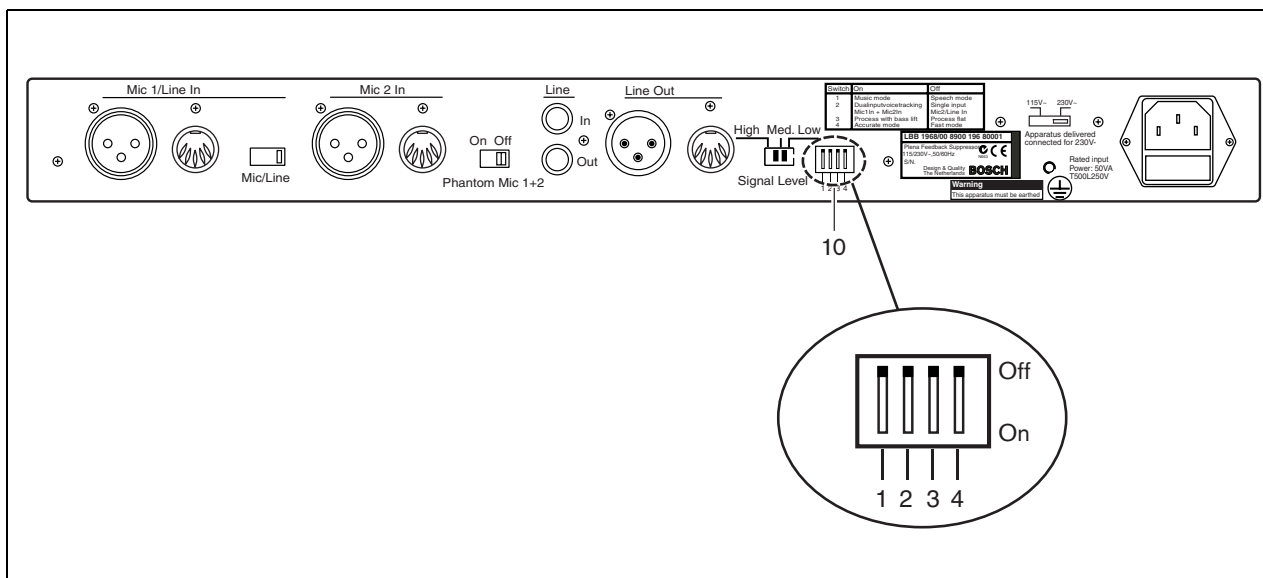

figure 3.6: Options switches

The Plena Feedback Suppressor is provided with four options switches (10):

table 3.3: Options switches

Switch number	ON-position	OFF-position
1	Music mode	Speech mode
2	Dual input Auto Mix (Mic 1 In + Mic. 2 In)	Single input (Mic 1/Line in)
3	Bass lift mode	Flat mode
4	Accurate filter mode	Fast filter mode

Music mode/Speech mode

In the Speech mode (not recommended for music) up to 12 dB extra gain is possible, compared to the bypass mode, before acoustic feedback occurs. The Speech mode (5 Hz frequency shift) is faster and more effective in feedback suppression than the Music mode.

In the Music mode (recommended for music, but also suitable for speech) up to 6 dB extra gain is possible before acoustic feedback occurs, depending on the acoustical environment.

Dual input Auto Mix mode

In this mode the Auto Mix function (see §1.1) is enabled.

Bass lift mode/Flat mode

Due to natural room reverb e.g. a speaker's voice will normally sound full and rich. As feedback suppression, using the de-reverberation algorithm, filters and reduces the room reverb, this may cause the low frequency response of the room to be less pronounced, especially in larger halls. The 'Bass lift' option is provided to correct this phenomenon.

Accurate mode/Fast mode

The adaptive filter can be switched between a Fast filter mode and an Accurate filter mode. In the Fast filter mode the system converges faster. As a consequence, this mode is suitable for situations where the microphone position changes over time, e.g. in case of a handheld microphone or in a discussion system with multiple switching microphones.

The Accurate filter mode is for situations with a fixed microphone position, e.g. on a pulpit. Then the acoustical environment is more stable and the adaptive filter is allowed to converge more slowly to suppress the reverb components even more.

Position of the options switches

The table below shows the recommended position of the options switches for the specific configuration set-ups described in §3.1.

table 3.4: Configuration set-ups and options switches positions

Configuration	Position of the options switches			
	switch 1	switch 2	switch 3	switch 4
Announcement set-up	Speech mode	Dual input voice tracking	Any position	Fast filter mode
Live performance set-up	Music mode	Single input	Any position	Fast filter mode
Conference set-up	Speech mode	Single input	Any position	Fast filter mode
Presentation set-up	Speech mode	Dual input voice tracking	Any position	Fast filter mode
Churches, houses of worship set-up	Music mode	Dual input voice tracking	Any position	Accurate filter mode

3.3 Mains connection

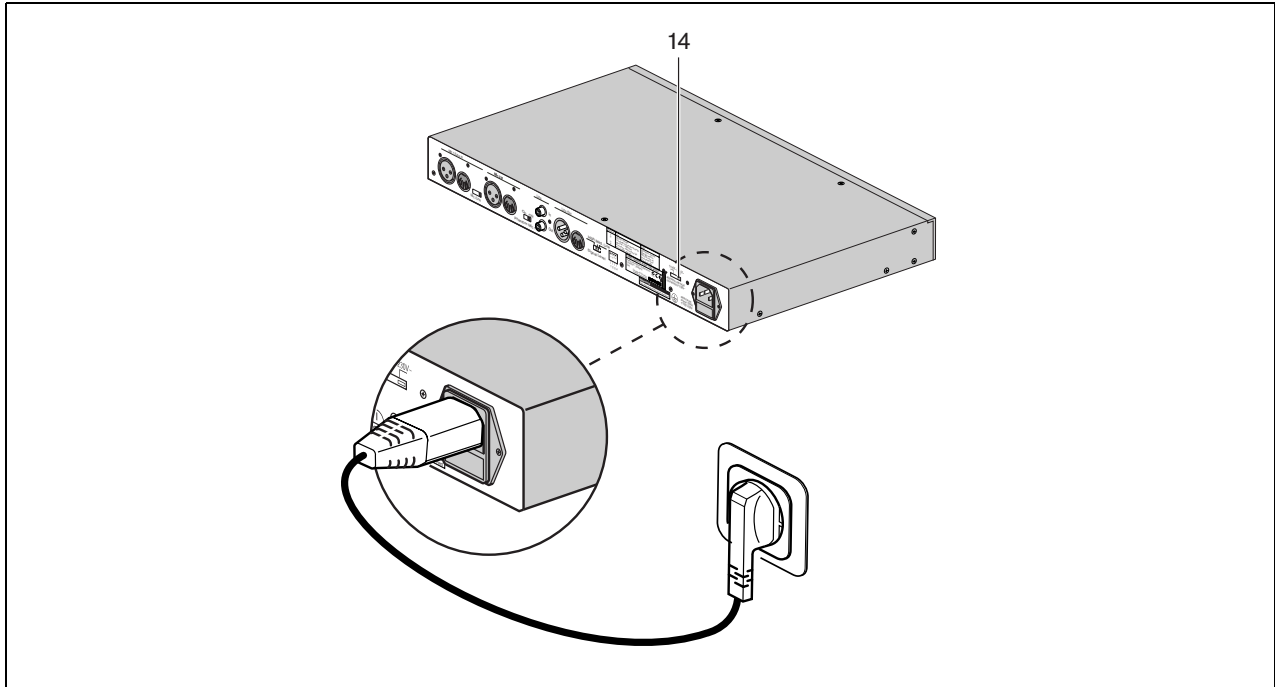

figure 3.7: Mains connection

Use the supplied mains cord to connect the system to the mains supply.



Note

If necessary set the mains voltage selection switch (14) to the required voltage using a sharp object, e.g. a small screwdriver.

4 Operation of the feedback suppressor

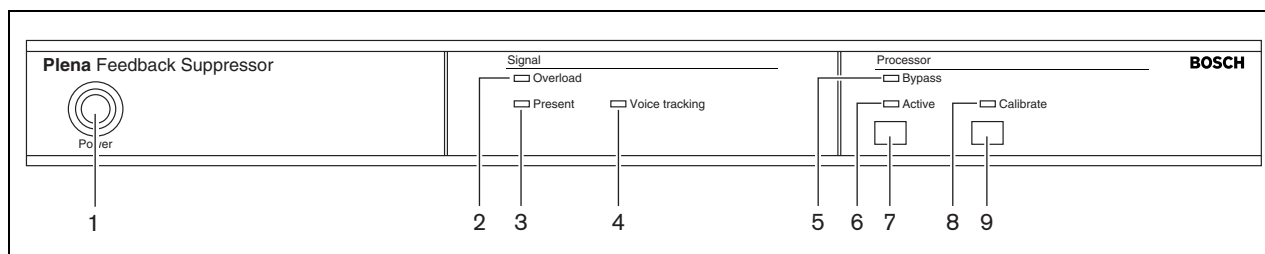

figure 4.1: Controls and indicators (front)

4.1 Switching ON

- Make sure that all settings and connections (see §3.1 and §3.2) are correct.
- Set the master volume on the power amplifier to 0.
- Switch ON the Feedback Suppressor by pressing the power button (1).
- Enable automatic feedback suppression by pressing the bypass switch (7). The feedback suppression active indicator (6) will light up to indicate that the feedback suppression algorithm is active.
- Increase the master volume to the desired level.



Note

It is recommended to test the gain margin by increasing the volume with another 3 dB to test for feedback, should a higher volume be required later on.



Note

Keep in mind that, contrary to traditional feedback reduction systems, the Plena Feedback Suppressor suppresses feedback **before it occurs**. Consequently, deactivating the suppression algorithm may lead to immediate feedback.

4.2 Calibration

The Plena Feedback Suppressor requires a source signal in order to measure the acoustic environment and to set the adaptive filter. When no such signal is present (e.g. before the event or the conference):

- Press the calibrate button (9). Random noise at -6 dBr will be generated for a few seconds to allow the feedback suppression algorithm to calibrate quickly. During this time, the calibrate indicator (8) will light up.

or

- Make sure there is a source signal, e.g. by playing some background music.

When the unit perceives a too high input signal, the input signal overload indicator (2) lights up. In this case, adjust the input signal level using the signal level switches on the rear of the unit.

When howling noises are heard, the Feedback Suppressor is operating at its feedback suppression limit. In this case, decrease the overall signal gain (e.g. by decreasing the microphone gain on the mixing panel or by decreasing the master volume on the power amplifier).

4.3 General recommendations to prevent feedback

- Ensure correct arrangement of microphones and loudspeakers. Pay special attention to the directivity of the microphones and loudspeakers and to the proper distance between microphones and loudspeakers. This applies especially to buildings with long reverberation times, such as houses of worship.
- Always use the microphones and loudspeakers according to the manufacturer's specifications.
- Improve poor and reverberating room acoustics, e.g. by covering highly reflective (tiled) walls and floors with curtains or carpets.
- Never use loudspeakers above their rated power. Due to power compression of the loudspeakers, the feedback margin is reduced. Try to ensure enough headroom.

5 Technical data

5.1 Electrical

Mains voltage	230/115 Vac, $\pm 10\%$, 50/60 Hz
Max mains power consumption	50 VA
Max mains inrush current	1.5 A @ 230 Vac / 3 A @ 115 Vac

5.2 Performance

Sample rate (fs)	32 kHz
Frequency response	125 Hz - 15 kHz (Speech mode) 20 Hz - 15 kHz (Music mode)
Distortion	< 0.1% @ 1 kHz
Gain	0 dB Line in 24 / 36 / 48 dB Mic in
S/N	> 90 dB
Signal delay	7 ms (bypass and Music mode) 11 ms (Speech mode)
Decorrelator	Frequency shift, 5 Hz up (Speech mode) Masked noise (Music mode)

5.3 Inputs

Line / Mic input 1 (3-pin XLR, 5-pin DIN, balanced)

Max. input level	18 / 6 / -6 dBV (Line, Hi / Med / Lo level) -18 / -30 / -42 dBV (Mic, Hi / Med / Lo level)
Impedance	10 kOhm / 2 kOhm (Line / Mic)
CMRR	> 25 dB (50 Hz - 20 kHz)
Phantom power	16 V (Mic only, switchable)
Priority control	Loophrough of pin 4 and 5 of DIN (for microphones with priority switch)

Mic input 2, Mic (3-pin XLR, 5-pin DIN, balanced)

Max. input level	-18 / -30 / -42 dBV (Hi / Med / Lo level)
Impedance	2 kOhm
Phantom power	16 V (switchable)
Priority control	Loophrough of pin 4 and 5 of DIN (for microphones with priority switch)

Line input 3, Line (Cinch, unbalanced)

Max. input level	18 / 6 / -6 dBV (Hi / Med / Lo level)
Impedance	20 kOhm

5.4 Outputs

Line output 1 (3-pin XLR, balanced)

Max. output level	18 / 6 / -6 dBV (Line in, Hi / Med / Lo level) 6 dBV (Mic in)
Impedance	< 100 Ohm

Line output 2 (Cinch, unbalanced)

Max. output level	18 / 6 / -6 dBV (Line in, Hi / Med / Lo level) 6 dBV (Mic in)
Impedance	< 100 Ohm

Mic output 3 (5-pin DIN, balanced)

Max. output level	-22 / -34 / -46 dBV (Line in, Hi / Med / Lo level) -34 dBV (Mic in)
Impedance	< 100 Ohm
Priority control	Loophrough of pin 4 and 5 of DIN from inputs

5.5 Controls and indicators

Power switch	
Bypass / Active switch	with yellow and green LED
Calibrate button	to start fast calibration cycle
Signal indicators	Overload @ 0 dBr, red Present @ -40 dBr, green Auto Mix enabled, green Calibrate, yellow

5.6 Environmental conditions

Operating temperature range	-10 to +55 °C
Storage temperature range	-40 to +70 °C
Relative humidity	< 95%

5.7 General

EMC emission	acc. to EN 55103-1
EMC immunity	acc. to EN 55103-2
Dimensions	56 x 430 x 270 mm (with feet, without mounting brackets) 19", 1U high (with mounting brackets, without feet)
Weight	approx. 3 kg
19" mounting brackets	included

For more information visit
www.boschsecuritysystems.com

© Bosch Security Systems B.V.
Data subject to change without notice
2003-11 | 9922 141 81681en

BOSCH