



# AVENAR detector 4000

FAP-425 / FAH-425



**BOSCH**

**en** Operation Guide



## Table of contents

<b>1</b>	<b>Product Description</b>	<b>4</b>
<b>2</b>	<b>System Overview</b>	<b>5</b>
2.1	Functional Description of the Sensor Technology	5
2.1.1	Optical Sensor (Smoke Detector)	5
2.1.2	Thermal Sensor (Heat Detector)	5
2.1.3	Chemical Sensor (Gas Sensor)	6
2.2	System Description	6
2.3	Flash Frequency and Error Detection	6
2.4	Features	6
2.5	Accessories	7
2.5.1	Remote Indicators	9
<b>3</b>	<b>Planning</b>	<b>13</b>
3.1	Basic Installation/Configuration Notes	13
3.2	Use in a Local Security Network (LSN/LSN improved version)	13
<b>4</b>	<b>Programming</b>	<b>14</b>
4.1	FAP-425-DOTC-R	14
4.2	FAP-425-DOT-R / FAP-425-OT-R / FAP-425-OT	15
4.3	FAP-425-DO-R / FAP-425-O-R / FAP-425-O	16
4.4	FAH-425-T-R	17
<b>5</b>	<b>Connection</b>	<b>19</b>
5.1	Overview of Detector Bases	19
5.2	Installing the Base	20
5.3	Connection	21
5.3.1	Connecting the MS 400/MS 400 B	22
5.3.2	Connecting the FAA-MSR 420	22
5.4	Detector Base Sounders	23
5.5	Installation of the Detector Module	24
5.6	Detector Removal	25
5.7	Address Setting	25
<b>6</b>	<b>Order Information</b>	<b>27</b>
6.1	Detector Variants	27
6.2	Detector Bases	27
6.3	Detector Accessories	27
6.4	Installation Accessories	28
6.5	Detector Base Sounders	28
6.6	Service accessories	28
<b>7</b>	<b>Maintenance and Service</b>	<b>30</b>
7.1	Detector Type Encoding	30
7.2	Test Instructions for LSN improved version Fire Detectors	31
7.2.1	Test Instructions for All Fire Detectors With Optical Sensor	31
7.2.2	Test Instructions for FAP-425-DOTC-R / FAP-425-DOT-R / FAP-425-OT-R / FAP-425-OT	32
7.3	Diagnostic Data	32
7.4	Warranty	34
7.5	Repair	34
7.6	Disposal	34
<b>8</b>	<b>Technical Data</b>	<b>35</b>

# 1 Product Description

AVENAR detector 4000 combines standard detection procedures such as scattered light and temperature measurement with gas measuring technology at the highest configuration level. This method uses intelligent evaluation electronics (Intelligent Signal Processing - ISP) to evaluate the signals from the smoke, thermal and gas sensor. Thus, immunity against false alarms is increased significantly and detection time is reduced in comparison to the fire detectors available on the market today.

Thanks to the combined information collected by the multi-sensor detectors, they can be used in environments where simple smoke detectors cannot be employed.

AVENAR detector 4000 is suitable for surface and flush mounting and includes separate mounting points for dropped ceiling and concealed sockets.

AVENAR detector 4000 is available in different versions of single-sensor and multi-sensor detectors.

Identifier	Description	Material no.	Category
FAP-425-O-R	Optical smoke detector, automatic and manual address setting	F.01U.280.244	Single sensor
FAP-425-OT-R	Combined optical and thermal smoke detector, automatic and manual address setting	F.01U.280.245	Multi-sensor
FAP-425-O	Optical smoke detector, automatic address setting only	F.01U.279.893	Single sensor
FAP-425-OT	Combined optical and thermal smoke detector, automatic address setting only	F.01U.279.987	Multi-sensor
FAH-425-T-R	Thermal detector, automatic and manual address setting	F.01U.280.243	Single sensor
FAP-425-DO-R	Dual-optical smoke detector, automatic and manual address setting	F.01U.279.988	Double sensor
FAP-425-DOT-R	Combined dual-optical and thermal smoke detector, automatic and manual address setting	F.01U.279.989	Multi-sensor
FAP-425-DOTC-R	Combined dual-optical, thermal and chemical smoke detector, automatic and manual address setting	F.01U.280.451	Multi-sensor

## 2 System Overview

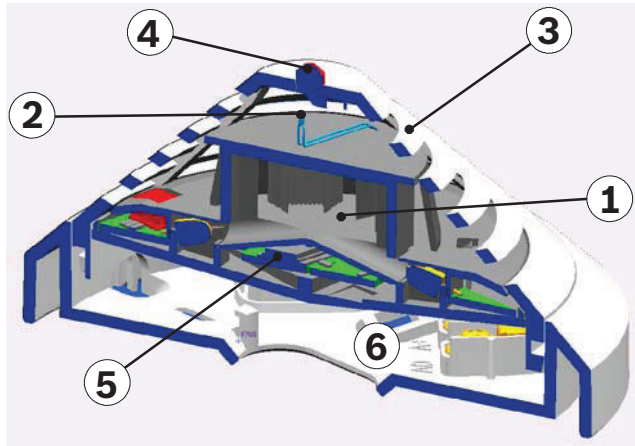

Figure 2.1: Detector set-up

1	Smoke measurement chamber with optical sensor	4	Individual display
2	Thermal sensor	5	PC board with evaluation electronics
3	Chemical sensor (covered on the cross-section)	6	MS 400 / MS 400 B Detector Base

### 2.1 Functional Description of the Sensor Technology

#### 2.1.1 Optical Sensor (Smoke Detector)

This optical sensor utilizes the scattered-light method.

An LED sends light into the measuring chamber, where it is absorbed by the labyrinth structure. In the event of a fire, smoke enters the measuring chamber. The light is scattered by the smoke particles and hits the photo diodes, which transform the quantity of light into a proportional electrical signal.

The DO detectors have a dual optical sensor that uses the different infrared and blue light wavelengths (Dual Ray technology). This allows fires to be detected early and even the smallest quantities of smoke (TF1, TF9) to be reliably detected.



**Notice!**

The FAP-425-DO-R smoke detector makes an alarm decision based on an intelligent combination of the following criteria:

- Amount of smoke density measured
- Speed of smoke density increase
- Size of smoke particles (as measured by Dual Ray technology)

#### 2.1.2 Thermal Sensor (Heat Detector)

A thermistor in a resistance network is used as a thermal sensor; an analog-digital converter measures the temperature-dependent voltage at regular intervals.

Depending on the specified detector class, the thermal sensor triggers the alarm status when the maximum temperature of 54 °C or 69 °C is exceeded (thermal maximum), or if the temperature rises by a defined amount within a specified time (thermal differential).

### 2.1.3 Chemical Sensor (Gas Sensor)

The gas sensor detects mainly the carbon monoxide (CO) that is produced by a fire, but it also detects hydrogen (H) and nitrogen monoxide (NO).

The underlying measurement principle is CO oxidation and the measurable current that it creates. The sensor signal value is proportional to the concentration of gas.

The gas sensor supplies additional information in order to reliably suppress disturbance variables.

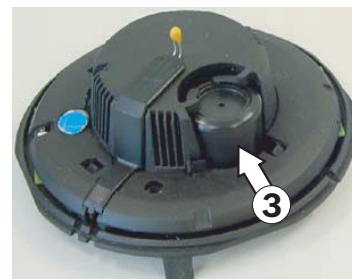

Chemical sensor

## 2.2 System Description

Up to three detection principles are integrated in FAP-425/FAH-425 series detectors:

- Optical (for smoke): O
- Dual-optical (for smoke): DO
- Thermal (for heat): T
- Chemical (for CO gas): C
- Detector with rotary switch: R, automatic and manual addressing

The individual sensors are programmed via the LSN network manually or using a timer. All sensor signals are analyzed continually by the internal signal analysis electronics (ISP) and are linked with each other. By linking the sensors (combined detectors), the detector can also be used in places where the work carried out gives rise to light smoke, steam or dust. If a signal combination fits the selected identifier for the area of operation for the detectors, an alarm is triggered automatically.

## 2.3 Flash Frequency and Error Detection

The LSN improved detector has two centrally positioned two-color LEDs that flash green to display the operational status.

The green LED on LSN improved FAP-425/FAH-425 series detectors is deactivated when delivered. It can be activated as required via the programming software.

The LSN improved detector permanently monitors and adjusts itself throughout its life cycle in order to adapt its sensitivity to the set threshold value.

A message is sent to the fire panel if the detector becomes too contaminated.

The LED will start to flash red as soon as an alarm is triggered.

The detector will return to its normal operating condition when the alarm is canceled via the control panel or if the alarm cause disappears.

## 2.4 Features

- Active self-monitoring of the sensors, with display on the fire panel:
  - Active adjustment of the threshold (drift compensation) if the optical sensor becomes contaminated.
  - Active adjustment of the threshold (drift compensation) of the chemical sensor.
- EMC safety is 50 V/m and is therefore much higher than normatively required.
- Preservation of LSN loop functions in the event of wire break or short-circuit of a detector through integrated isolators.
- Individual detector identification on the fire panel in the event of an alarm. Alarm indication on the detector with a flashing red LED.
- Programmable, i.e. can be adjusted to the area of operation.

- Increased detection and false alarm security thanks to evaluation of the temporal behavior of fire and disturbance variables.
- Activation of a remote indicator is possible.
- Optional mechanical removal safeguard (can be activated/deactivated).
- Dust-resistant labyrinth and cap construction.
- Every detector base has a Chamber Maid Plug (a cleaning opening with a plug) for blowing out the optical chamber with compressed air (not required for the FAH-425-T-R Heat Detector).
- For connecting to the FPA-5000 and FPA-1200 fire panels with extended range of LSN features.
- In classic mode, can be connected to the BZ 500 LSN, UEZ 2000 LSN and UGM 2020 LSN fire panels and to other panels or their receiver modules with identical connection properties but with the existing LSN system limits.
- It is possible to read out the serial number, contamination level (for the O sensor), operating hours, EMC strength level and current analog values for each configured detector via LSN.
- Use of shielded and unshielded cables.
- The LSN improved version line technology supports the connection of up to 254 FAP-425/FAH-425 series detectors per loop or stub (please observe national regulations in this regard).
- Flexible network structures without additional elements are possible (T-tapping is not feasible with detector versions without rotaries).
- Automatic or manual detector addressing selectable.
- Compliant with EN 54, EN 50131 and VdS guidelines.

**For DO detectors, note:**



**Notice!**

The device cannot be used with the FPA-5000 type A panel controller.

## 2.5

### Accessories

#### FLM-320-EOL2W EOL Module

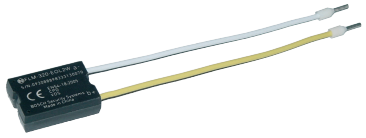
<p><b>FLM-320-EOL2W EOL Module</b></p>	
<p>The FLM-320-EOL2W EOL module is a 2-wire module for terminating a line according to EN 54-13. The module detects faults according to EN 54-13 and reports errors to the fire panel.</p>	

#### Support Plates

The support plates are made from 1.8 mm thick ABS plastic and are clamped between the detector base and the ceiling.

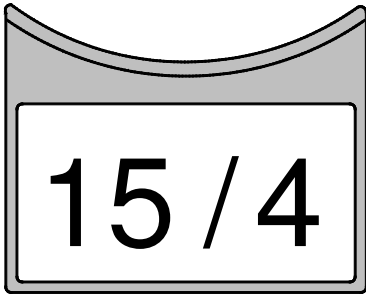
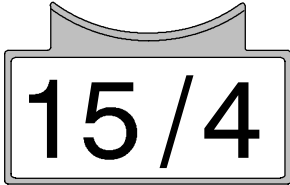
<p><b>TP4 400 Support Plate</b></p> <p>The TP4 400 Support Plate is intended for an installation height up to 4 m and is designed for labels up to a size of approx. 65 x 34 mm.</p>	
<p><b>TP8 400 Support Plate</b></p> <p>The TP8 400 Support Plate is intended for an installation height up to 8 m and is designed for labels up to a size of approx. 97 x 44 mm.</p>	

#### SK 400 Protective Basket

The SK 400 Protective Basket is installed over the detector and gives the detector substantial protection against damage.

If the detector is mounted in a sports facility, for example, the protective basket prevents balls or other sports equipment from hitting the detector and damaging it.

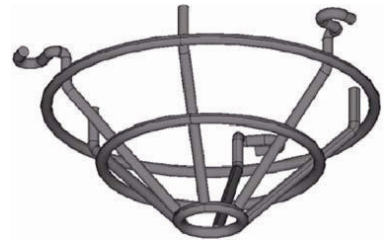

#### SSK 400 Protective Dust Cover

The SSK 400 Protective Dust Cover is necessary during construction work to protect an installed detector base, with or without detector module, from contamination. The protective dust cover made of polypropylene (PP) is pushed onto the installed detector base.

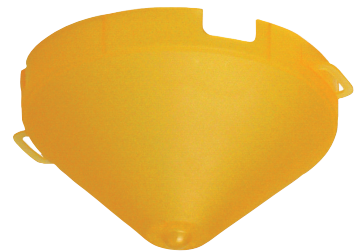

#### MK 400 Detector Console

The MK 400 Detector Console is used to install detectors above door frames or similar in compliance with DIBt. The console is supplied with a pre-mounted MS 400 Detector Base (the detector shown is not included in the scope of delivery).





### MH 400 Detector Heating Element

The MH 400 Detector Heating Element is required if the detector is used in an environment where water condensation can occur, such as in a warehouse that must frequently be opened briefly for delivery vehicles.

The detector heating element is connected to the + V/0 V terminals in the detector base.

Operating voltage: 24 V DC

Resistance: 1 k $\Omega$

Power consumption: 3 W.

The heating is supplied with power either by the fed-through supply voltage via the central unit or by a separate power pack.

With supply via the central unit, the number of detector heating elements depends on the cable diameter and line length used.



## 2.5.1

### Remote Indicators

A remote indicator is required if the detector is not directly visible or has been mounted in false ceilings or floors. The remote indicator should be installed in corridors or access pathways to the corresponding building sections or rooms.

#### Installation of the FAA-420-RI Remote Indicator

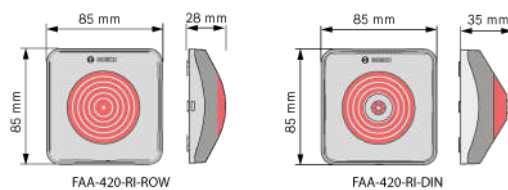

#### Warning!

Malfunction and Damage

If maximum current consumption of the connected detector is larger than 20 mA, it can result in malfunction and damage to the remote indicator.

Before assembly remove the cap from the base plate

1. Unlock the snap-fit hook by pressing on it with a flat object and lift the cap carefully
2. Remove the connection board for easy access.
3. Mount the base plate directly on a dry, level surface with two or four screws.

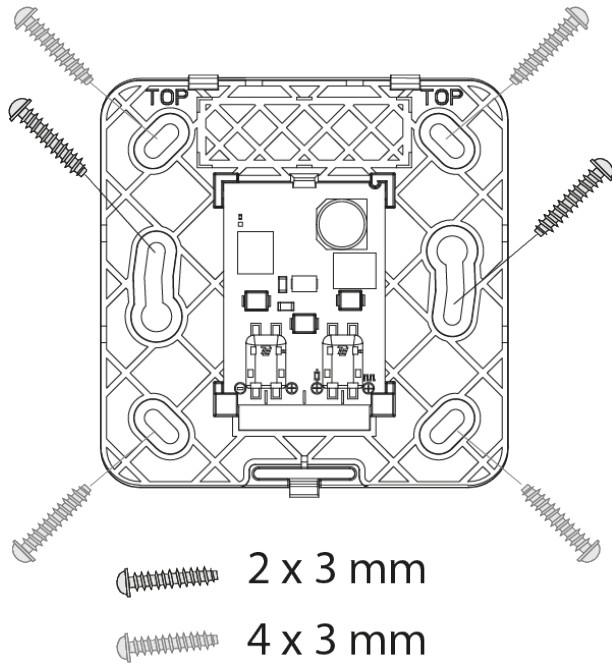

1. For surface-mounted cables, break out the prepunched cable entries.

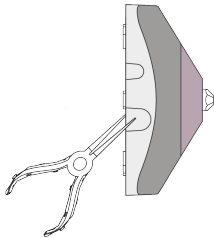

2. For flush-mounted cables, insert the cable through the opening under the connection board.

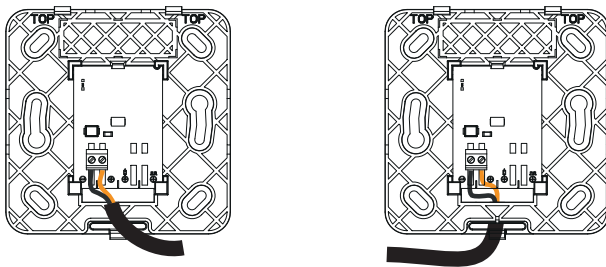

3. Secure the cable with a zip tie on the base plate.

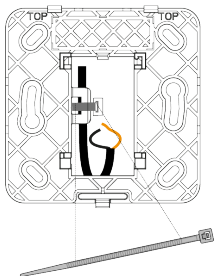

**Wiring FAA-420-RI-ROW**

1. Wire the remote indicator as shown.

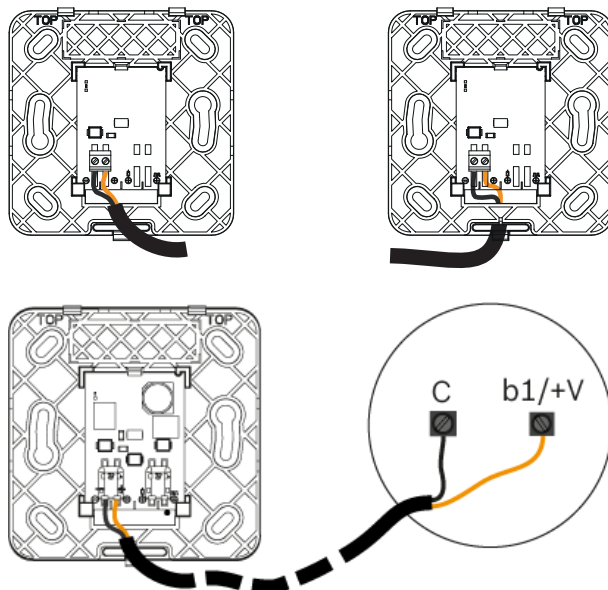

2. Place the cap on the base plate in such a way that the two hooks are inserted into the slits.
3. Press the cap lightly onto the base plate until the snap-fit-hook engages.

**Wiring FAA-420-RI-DIN**



**Warning!**

Malfunction and Damage

Note the maximum permitted current supply respectively the input voltage range of the functional modes.

- ▶ Wire the remote indicator as shown.

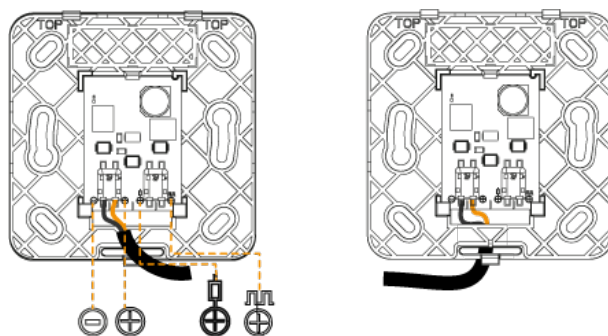

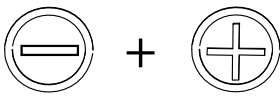
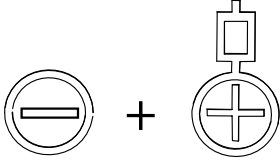
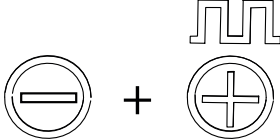
Mode	Terminal connection	Alarm condition
1		The remote indicator shows steady red light. Current has to be limited to max. 30 mA.
2		The remote indicator shows steady red light. Input voltage range: 8.5 V DC ... 33 V DC. Constant current consumption 13 mA.
3		The remote indicator shows flashing red light. Input voltage range: 11 V DC ... 33 V DC. Constant current consumption 3 mA.

Operate in mode 1 and 3 only, when connected to LSN detectors.

1. Place the cap on the base plate in such a way that the two hooks are inserted into the slits.
2. Press the cap lightly onto the base plate until the snap-fit-hook engages.



#### Notice!

##### Malfunction

The cable length between the detector and the remote indicator must not exceed 3 m when connected by an unshielded cable.

#### Technical specifications

	FAA-420-RI-ROW	FAA-420-RI-DIN
Operating Voltage	5 - 30 V DC	9 - 30 V DC
Maximum current consumption	20 mA	Mode 1: limited to 30 mA Mode 2: 13 mA Mode 3 : 3 mA
Permissible wire gauge	0,6 – 2 mm	0,6 - 0,8 mm
Display medium	1 LED	2 LED
Dimensions	85 x 85 x 28 mm	85 x 85 x 35 mm
Weight	45 g	65 g

## 3 Planning



### Notice!

FAP-425/FAH-425 Automatic Fire Detectors are not designed for exterior use.

### 3.1 Basic Installation/Configuration Notes

- Multi-sensor fire detectors must be planned in line with the guidelines for optical detectors until a guideline for their planning is developed in collaboration with the VdS (see also DIN VDE 0833 Part 2 and VDS 2095):
  - Maximum monitoring area 120 m<sup>2</sup>.
  - Maximum installation height 16 m.
- If occasional switch-off of the optical sensor is required, the planning must occur according to the guidelines for heat detectors (see DIN VDE 0833 Part 2 and VDS 2095):
  - Maximum monitoring area 40 m<sup>2</sup>.
  - Maximum installation height 7.5 m.
- Maximum permissible air speed: 20 m/s.
- FAH-425-T-R detectors must be configured according to Class A1R when planning fire barriers conforming to DIBt.

### 3.2 Use in a Local Security Network (LSN/LSN improved version)

In a Local Security Network, the detectors connected to a fire panel can be operated in the following operating modes:

Detector Type	Operating mode			
	Combined	Optical	Thermal maximum	Thermal differential
FAP-425-OT-R/ FAP-425-OT	X	X	X	X
FAP-425-O-R/ FAP-425-O	-	X	-	-
FAH-425-T-R	-	-	X	X
FAP-425-DO-R	-	X	-	-
FAP-425-DOT-R	X	X	X	X
FAP-425-DOTC-R	X	X	X	X



### Notice!

Planning should take the anticipated total current and line resistance into account to ensure each detector has an operating voltage of at least 15 V DC.

## 4 Programming

Programming occurs via a PC or laptop connected to the fire panel with FSP-5000-RPS (Remote Programming System) for panels with LSN improved version line technology. The FAP-425/FAH-425 series detectors are programmed by entering the area of operation. The selection of the area of operation determines the optimum characteristic field for fire and disturbance variable evaluation.

When optical sensor sensitivity in the FAP-425-DOTC-R is low, the detector only triggers if both smoke and an increase in CO concentration or temperature is detected.

The operating mode can be changed for the FAP-425-OT-R/FAP-425-OT detector models, as well as the FAP-425-DOTC-R and FAP-425-DOT-R models, i.e. individual sensors can be switched off:

- Switch to optical (O sensor sensitivity = low, T sensor = switched off)
- Switch to thermal differential (T sensor sensitivity = A2R, O sensor = switched off)
- Switch to thermal maximum (T sensor sensitivity = A2S, O sensor = switched off).

In the case of the purely optical FAP-425-O-R/FAP-425-O and FAP-425-DO-R detectors, the sensitivity of the optical sensor can be set to three levels. Depending on the operating location, the optical sensor in the detector is thus adjusted to the environmental conditions.

### Notice!



For fire detection, the purely optical detector also evaluates the time behavior of the fire characteristics, which differs significantly from the time behavior of disturbance variables and that occurring during a detector test

As a result, there are also different trigger times when testing with a test aerosol outside of Walk test operation (10 s to max 60 s), depending on the selected sensitivity adjustment.

The FAH-425-T-R is programmed by taking into account the ambient temperature, the installation height and the sensitivity class selection.

Programming of the optical, thermal, and chemical sensors and the linking of all sensors via algorithms significantly increases the detection ability and security against false alarms.

### 4.1 FAP-425-DOTC-R



#### Notice!

The default setting of the FAP-425-DOTC-R detector in RPS is "Office (smoker) / Waiting Room / Restaurant / Meeting Room". For a description of this setting, see the below table.

Selectable installation locations in the programming software (FSP-5000-RPS)	Detector Type	Sensitivity		
		Thermom ax (T <sub>max</sub> )	Optical (O)	Chemical (C)
Office (after hours)	O, T <sub>max</sub> , T <sub>diff</sub> , C	High (A2)	High	High
<b>Office (smoker)/waiting room/ restaurant/meeting room = default setting</b>	<b>O, T<sub>max</sub>, T<sub>diff</sub>, C</b>	<b>High (A2)</b>	<b>Low*</b>	<b>Low</b>
Office (day mode)	O, T <sub>max</sub> , T <sub>diff</sub> , C	Low (B)	Medium	High
EDP room	O, T <sub>max</sub> , T <sub>diff</sub> , C	High (A2)	High	High

Selectable installation locations in the programming software (FSP-5000-RPS)	Detector Type	Sensitivity		
		Thermom ax (T <sub>max</sub> )	Optical (O)	Chemical (C)
Production location	O, T <sub>max</sub> , T <sub>diff</sub> , C	Low (B)	Low*	Medium
Garage	O, T <sub>max</sub> , T <sub>diff</sub> , C	High (A2)	Low*	Low
High storage warehouse without vehicle traffic with combustion engine	O, T <sub>max</sub> , T <sub>diff</sub> , C	Low (B)	High	High
Conference hall/waiting room/fairground	O, T <sub>max</sub> , T <sub>diff</sub> , C	High (A2)	Low*	Medium
Kitchen/casino/restaurant during active operation	O, T <sub>max</sub> , C	Low (B)	Low*	Low
Warehouse with vehicle traffic	O, T <sub>max</sub> , T <sub>diff</sub> , C	Low (B)	Low*	Low
Rate of rise only (optical sensor off)	T <sub>max</sub> , T <sub>diff</sub>	High (A2)	-	-
Optical only (thermal sensor off)***	O	-	Low	-
Fixed temperature heat only (optical sensor off)	T <sub>max</sub>	High (A2)	-	-
Optical/chemical (thermal sensor off)***	O, C	-	Low	High
Schools/kindergarten	O, T <sub>max</sub> , T <sub>diff</sub> , C	High (A2)	Medium	High
Theater/concert hall	O, T <sub>max</sub> , T <sub>diff</sub> , C	High (A2)	Medium	High
<p>O = optical sensor                      T<sub>max</sub> = thermal maximum unit                      T<sub>diff</sub> = thermal differential unit                      C = chemical sensor                      * If optical sensor sensitivity is low, the detector will only trigger if smoke as well as an increase in CO concentration or temperature is detected.                      *** For FAP-425-DOTC-R: does not comply with EN54-7                      For details on installation height, see <i>FAH-425-T-R</i>, page 17</p>				

## 4.2 FAP-425-DOT-R / FAP-425-OT-R / FAP-425-OT



**Notice!**

The default setting of the FAP-425-DOT-R, FAP-425-OT-R and FAP-425-OT detector types in RPS is "Office (day mode)". For a description of this setting, see the below table.

Selectable installation locations in the programming software (WinPara and FSP-5000-RPS)	Detector Type	Sensitivity	
		Thermomax (T <sub>max</sub> )	Optical (O)
Office (after hours)	O, T <sub>max</sub> , T <sub>diff</sub>	High (A2)	High
Office (smoker)/waiting room/restaurant/meeting room	O, T <sub>max</sub> , T <sub>diff</sub>	High (A2)	Low
<b>Office (day mode) = default setting</b>	<b>O, T<sub>max</sub>, T<sub>diff</sub></b>	<b>Low (B)</b>	<b>Medium</b>
EDP room	O, T <sub>max</sub> , T <sub>diff</sub>	High (A2)	High
Production location	O, T <sub>max</sub> , T <sub>diff</sub>	Low (B)	Low
Garage – FAP-425-OT-R, FAP-425-OT – FAP-425-DOT-R	T <sub>max</sub> , T <sub>diff</sub> T <sub>max</sub> , T <sub>diff</sub>	High (A2) High (A2)	- Low
High storage warehouse without vehicle traffic with combustion engine	O, T <sub>max</sub> , T <sub>diff</sub>	Low (B)	High
Conference hall/waiting room/fairground	O, T <sub>max</sub> , T <sub>diff</sub>	High (A2)	Low
Kitchen/casino/restaurant during active operation	T <sub>max</sub>	Low (B)	-
Warehouse with vehicle traffic	O, T <sub>max</sub> , T <sub>diff</sub>	Low (B)	Low
Rate of rise only (optical sensor off)	T <sub>max</sub> , T <sub>diff</sub>	High (A2)	-
Optical only (thermal sensor off)	O	-	Low
Fixed temperature heat only (optical sensor off)**	T <sub>max</sub>	High (A2)	-
Schools/kindergarten	O, T <sub>max</sub> , T <sub>diff</sub>	High (A2)	Medium
Theatre/concert hall	O, T <sub>max</sub> , T <sub>diff</sub>	High (A2)	Medium
O = optical sensor (dual-optical in FAP-425-DOT-R detectors) T <sub>max</sub> = thermal maximum unit T <sub>diff</sub> = thermal differential unit For details on installation height, see <i>FAH-425-T-R</i> , page 17			

### 4.3

### FAP-425-DO-R / FAP-425-O-R / FAP-425-O



#### Notice!

The default setting of the FAP-425-DO-R, FAP-425-O-R and FAP-425-O detector types in RPS is "Medium". For a list of possible installation locations and corresponding sensitivity settings, see the below table.



Installation locations	Selectable sensitivity
Theater/concert hall	Medium
Warehouse with vehicle traffic	Low
Office (smoker)/waiting room/restaurant/meeting room	Low
Conference hall/waiting room/fairground	Low
Office (after hours)	High
School/kindergarten	Medium
Production location	Low
EDP room	High
High storage warehouse without vehicle traffic with combustion engine	High
Office (day mode)	Medium

## 4.4

### FAH-425-T-R

Selectable installation locations in the programming software (FSP-5000-RPS)	
<b>A2R *</b>	<b>Typical application temperature: 25 °C, <math>T_{max} + T_{diff}</math>, height up to 6 m</b>
A2S	Typical application temperature: 25 °C, only $T_{max}$ , height up to 6 m
A1R	Typical application temperature: 25 °C, $T_{max} + T_{diff}$ , height 6 m to 7.5 m
A1	Typical application temperature: 25 °C, only $T_{max}$ , height 6 m to 7.5 m
BR	Typical application temperature: 40 °C, $T_{max} + T_{diff}$ , height up to 6 m
BS	Typical application temperature: 40 °C, only $T_{max}$ , height up to 6 m
* = Default setting in FSP-5000-RPS programming software	

#### Sensitivity classes as per EN 54 Part 5

With the detector types FAH-425-T-R, it is possible to set one of the sensitivity classes listed above in line with planning.

In the sensitivity classes A1, A2S and BS, the FAH-425-T-R is operated purely as a thermal maximum detector. In this case, the detector does not activate at below 54 °C in class A2S, and not below 69 °C in class BS.

The sensitivity classes A2S and BS are therefore particularly suitable for applications where higher temperature rates-of-rise occur over a longer period, e.g. in kitchens or boiler rooms. The sensitivity classes A1R, A2R and BR indicate that the thermal differential unit is active in addition to the thermal maximum unit.

These sensitivity classes are especially well-suited for use in unheated buildings where the ambient temperature can vary greatly but high temperature rates-of-rise do not last long. The thermal differential unit enables class A1R/A2R detectors to respond at  $T < 54$  °C and class BR detectors at  $T < 69$  °C.

The selection of the sensitivity class also depends on the installation height of the detector. To maintain the greatest possible security against false alarms, classes A1 and A1R should not be selected for room heights below 6 m, although these classes are in theory permitted. Furthermore, the expected application temperature must be taken into consideration.

Temperature rate-of-rise [K min <sup>-1</sup> ]	Response time for detectors in the sensitivity class A1R		Response time for detectors in the sensitivity classes A2R/BR	
	Lower limiting value [min/sec]	Upper limiting value [min/sec]	Lower limiting value [min/sec]	Upper limiting value [min/sec]
10	1 min	4 min 20 s	2 min	5 min 30 s
20	30 s	2 min 20 s	1 min	3 min 13 s
30	20 s	1 min 40 s	40 s	2 min 25 s

## 5 Connection

### 5.1 Overview of Detector Bases

Detectors in the FAP-425/FAH-425 series are operated in one of the detector bases listed below.

The detector bases are suitable for surface and flush mounting, and provide separate fixing points for ceiling and flush mount back boxes. They also fit all common bore patterns. The bases are made from white ABS plastic (color similar to RAL 9010) and have a matte surface finish.

The bases have screw terminals for connection of the detector and its accessories to the fire panel. Contacts connected with the terminals guarantee a secure electrical connection when installing the FAP-425/FAH-425 Detector Head. Cable diameters of up to 2.5 mm<sup>2</sup> can be used. The detector head can be secured against unauthorized removal with a variable lock.

#### MS 400

The MS 400 is the standard detector base. It has seven screw terminals.



#### MS 400 B

MS 400 standard detector base with Bosch-branding.



#### FAA-420-SEAL

For using the FAP/FAH detectors in damp environments you can supplement the MS 400 and MS 400 B detector bases with the FAA-420-SEAL damp room seal. The damp room seal is made of TPE and prevents condensing water from entering the detector.



**FAA-MSR 420**

The FAA-MSR 420 is a detector base with a change-over contact relay (type C).

The FAA-MSR 420 Detector Base with Relay can only be used in connection with the Local Security Network improved version (FPA-5000 Modular Fire Panel).

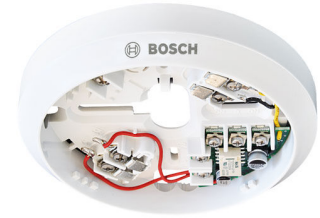
**MSC 420**

The MSC 420 Additional Base was designed specially for surface-mounted cable feed via cable protection conduits and has two opposing pre-cut entry points of 20 mm diameter and two additional opposing and prepared entry points for diameters up to 28 mm.

The additional base has a diameter of 120 mm and a height of 36.7 mm. To protect against condensed water penetration, a seal is placed on the bottom of the MSC 420.

**5.2****Installing the Base**

The detector bases are screwed to the even, dry surface using two screws approx. 55 mm apart.

To feed cables through for surface mounting, punch out the prepared entry points (X) on the housing.

For flush-mounted cable insertion, feed the cable through the opening in the middle of the base.

The long holes marked in the sketch with "Y" are intended for base installation in a flush mount back box and should only be used for this purpose.

**Notice!**

Cables can be fed in and out on the same side.

On the MSF 400 and MSC 420, punch out the integrated seal with a sharp tool. Do not cut with a knife.

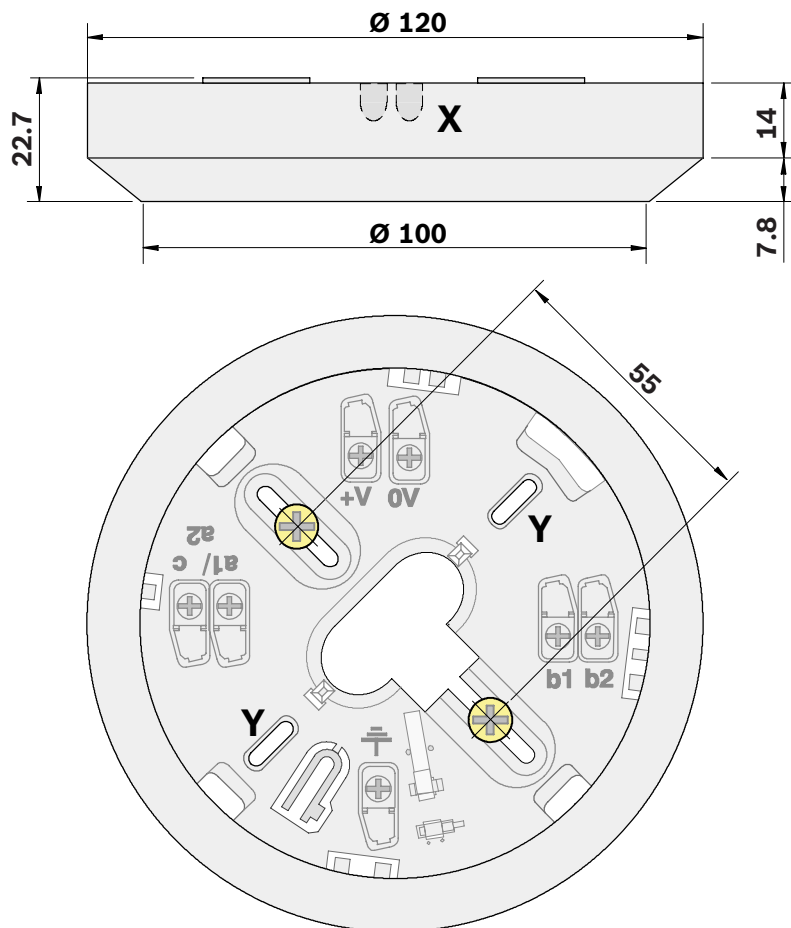

### 5.3 Connection



**Notice!**  
Keep shield wire as short as possible and insulate.

### 5.3.1 Connecting the MS 400/MS 400 B

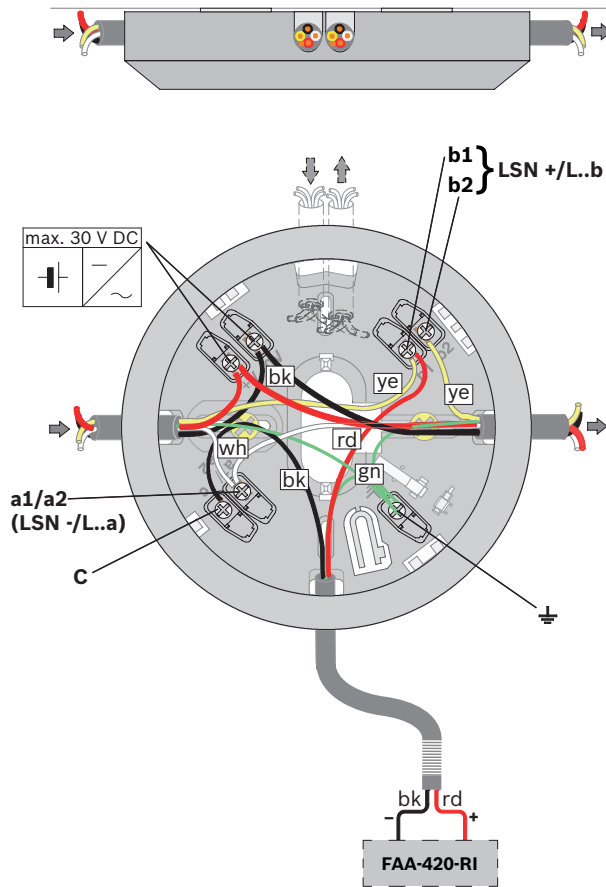

ye	Yellow, connection to b1/b2 (LSN +)
wh	White, connection to a1/a2 (LSN -)
rd	Red, connection to +V
bk	Black, connection to 0V
gn	Green, connection to shield wire
c	Indicator output
+V/0 V	Terminals for looping through the supply voltage for downstream elements
FAA-420-RI	Remote indicator

### 5.3.2 Connecting the FAA-MSR 420

Maximum contact load (resistive load) of the change-over contact relay:

- 62.5 VA: 0.5 A at 125 V AC
- 30 W: 1 A at 30 V DC

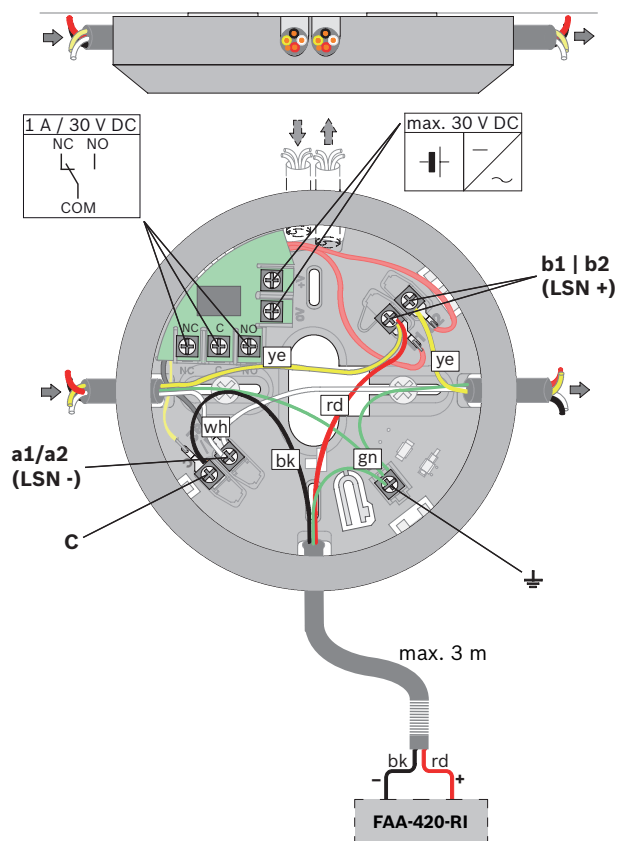

ye	Yellow, connection to b1/b2 (LSN +)
wh	White, connection to a1/a2 (LSN -)
rd	FAA-420-RI: Red, connection to b1
bk	FAA-420-RI: Black, connection to c (indicator output)
gn	Green, connection to shield wire
NC/C/NO	Change-over contact relay
+V/0 V	Terminals for looping through the supply voltage for downstream elements
FAA-420-RI	Remote indicator

## 5.4 Detector Base Sounders

Detector base sounders are used if acoustic alarm signaling is required directly at the fire source. Detector base sounders are available in four variants.

- MSS 300 Detector Base Sounder White, for conventional line technology, activation via the C point of the detector in use.
- MSS 300 WS-EC Detector Base Sounder White, for conventional line technology, with external activation (via an interface module).
- MSS 401 Detector Base Sounder White, for LSN line technology, with separate power supply.

The integrated tone generator has 11 tones for selection (incl. tones conforming to DIN 33404 and EN 457) with sound pressure of max. 100 dBA, depending on the type of tone selected.

With the LSN variants, the volume (4 levels) and also the tone type are programmed via the fire panel. The tone type on conventional variants is set via four DIP switches and the volume is adjusted continuously via a potentiometer.

FNM-420-A-BS Detector Base Sounder White or Red, for LSN line technology, with power supply via the LSN with 32 different tones

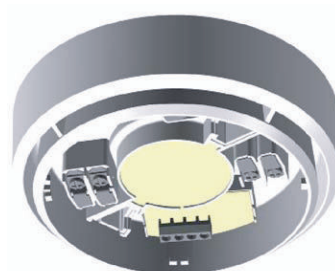

## 5.5 Installation of the Detector Module



**Notice!**

The packaging for the multisensor detector with C sensor consists of tear-proof PE-ALU laminated film and must be cut open carefully.

After installation and connection of the base, the detector head is set into the base and turned to the right as far as it will go.

Detector bases are delivered with inactive locks.

The detector module can be locked in the base (removal protection). The locking feature is activated by breaking the bolt (X) out of the base and pushing it into the corresponding guide, as shown in , page 24.



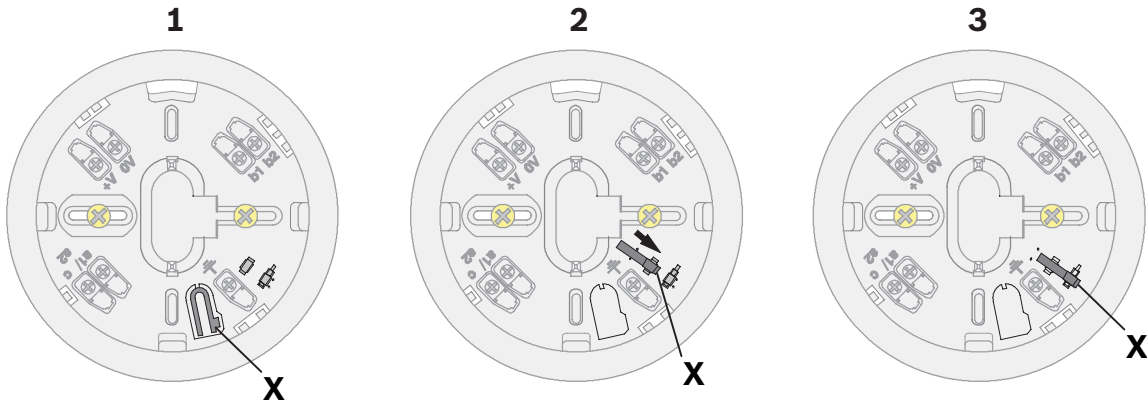

Figure 5.1: Activation of the removal protection mechanism

Key	
1	Bolt (X) before breaking out
2	Bolt (X) fitted, but deactivated
3	Locking activated

## 5.6 Detector Removal

Unlocked detector heads are disassembled by turning them to the left and removing them from the base.

Locked detector heads are disassembled by inserting a screwdriver into the unlocking opening (Y). At the first time removing the detector, push the screwdriver hard through the plastic to get to the bolt. Push the upward and turn the detector to the left at the same time.

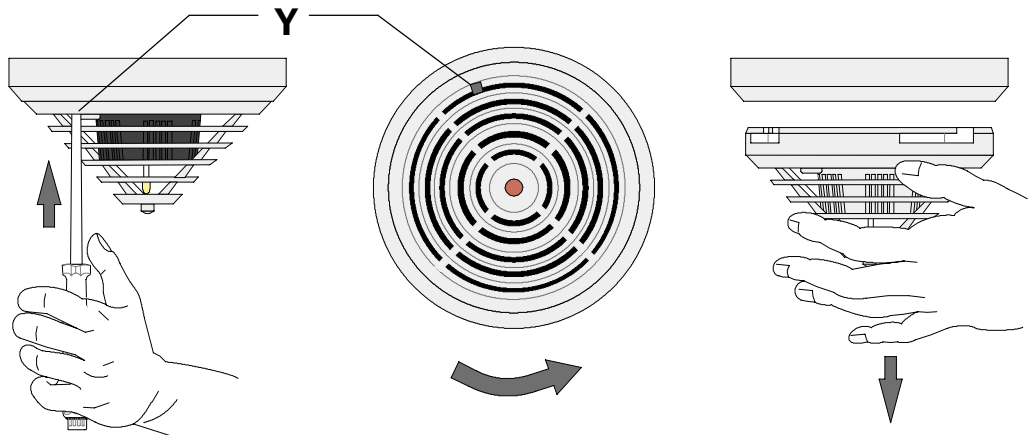

Figure 5.2: Detector removal (locked detector module)

### See also

- *Detector Removal, page 25*

## 5.7 Address Setting

The versions for automatic and manual address setting have three rotary switches on the bottom of the detector; these are used to select automatic or manual address allocation with or without auto-detection. The versions without rotaries are automatically addressable only. The following settings are possible:

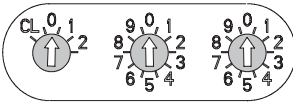
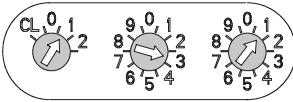
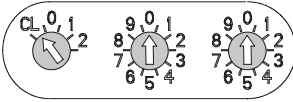
Rotary switch setting	Address	Operating mode
	0 0 0	Loop/stub with LSN improved version mode and automatic address allocation (T-tapping not possible) = delivery status
	0 0 1 ... 2 4 5	Loop/stub/T-tapping with LSN improved mode and manual address allocation (address shown in example = 131)
	CL 0 0	Loop/stub in classic LSN mode with automatic address allocation (T-tapping not possible, maximum number of elements = 127)

The rotary switches are moved to the required position using a slotted-head screwdriver.

**Automatic address allocation**

If addresses are automatically allocated by a fire panel with LSN improved version technology, all detectors must have the address "0 0 0" (delivery status).

For connection to classic LSN fire panels (BZ 500 LSN, UEZ 2000 LSN, UGM 2020), all detectors must have the address "CL 0 0".

**Manual address allocation**

For manual address allocation, the detector address is set with the three rotary switches. The right-hand rotary switch is used to set the units, the central rotary switch is used to set the tens and the left-hand rotary switch is used to set the hundreds.

**Notice!**



It is not permissible to use addresses greater than 254.

This will prompt the display of an error message on the fire panel.

All the detectors in a loop, stub or T-tap must have an address between 1 and 254 when addressed manually.

From LSN module software version 1.0.35, you can operate LSN improved version and LSN classic elements together in one loop or stub. If an LSN classic element is present, only 127 elements can be used in the loop.

Please note that only loop or stub structures can be used for configurations with mixed LSN classic and LSN improved elements.

## 6 Order Information

### 6.1 Detector Variants

Type number	Designation	Product ID
FAP-425-DOTC-R	Dual-optical, thermal, chemical multisensor detector, automatic and manual address setting	F.01U.280.451
FAP-425-DOT-R	Dual-optical, thermal multisensor detector, automatic and manual address setting	F.01U.279.989
FAP-425-OT-R	Multisensor Detector Optical/Thermal, automatic and manual address setting	F.01U.280.245
FAP-425-DO-R	Dual-optical smoke detector, automatic and manual address setting	F.01U.279.988
FAP-425-O-R	Optical Smoke Detector, automatic and manual address setting	F.01U.280.244
FAH-425-T-R	Heat Detector, automatic and manual address setting	F.01U.280.243
FAP-425-O	Optical Smoke Detector, automatic address setting only	F.01U.279.893
FAP-425-OT	Multisensor Detector Optical/Thermal, automatic address setting only	F.01U.279.987

### 6.2 Detector Bases

Type number	Designation	Product ID
MS 400	Standard detector base, for surface-mount and flush-mount cable insertion	4.998.021.535
MS 400 B	Standard detector base, for surface-mount and flush-mount cable insertion, Bosch-branded	F.01U.215.139
FAA-420-SEAL	Damp room seal for MS 400 and MS 400 B detector bases	F.01U.215.142
FAA-MSR 420	Detector Base with Relay	F.01U.508.658
MSC 420	Additional base with damp room seal, for surface-mount cable insertion	4.998.113.025

### 6.3 Detector Accessories

Type number	Designation	Product ID
FLM-320-EOL2W	EOL module 2-wire	F.01U.083.619
TP4 400	Support Plate for Detector Identification, installation heights up to 4 m (1 pack = 50 pieces)	4.998.084.709
TP8 400	Support Plate for Detector Identification, installation heights up to 8 m (1 pack = 50 pieces)	4.998.084.710

Type number	Designation	Product ID
SK 400	Protective Basket to guard against mechanical damage	4.998.025.369
SSK 400	Protective Dust Cover (1 pack= 10 pieces)	4.998.035.312
MH 400	Detector heating element	4.998.025.373

## 6.4 Installation Accessories

Type number	Designation	Product ID
MK 400	Detector Console, for DIBt-compliant detector installation above doors or similar, incl. detector base	4.998.097.924
FMX-DET-MB	Mounting bracket, with installation material for false floors, no detector base	2.799.271.257

## 6.5 Detector Base Sounders

Type number	Designation	Product ID
MSS 300	Detector Base Sounder White, conventional line technology, only C point activation via attached detector, for surface-mount and flush-mount cable insertion	4.998.025.372
MSS 300 WS-EC	Detector Base Sounder White, conventional line technology, only for external activation, for surface-mount and flush-mount cable insertion	4.998.120.501
FNM-420-A-BS-WH	Detector Base Sounder White, LSN, power supply via LSN, C point activation via attached detector or external activation via LSN, for surface-mount and flush-mount cable insertion	F.01U.064.687
MSS 401 LSN	Detector Base Sounder White, LSN, separate power supply required, C point activation via attached detector or external activation via LSN, for surface-mount and flush-mount cable insertion	4.998.102.859

## 6.6 Service accessories

Type number	Designation	Product ID
SOLO200	Detector Removal Tool	4.998.112.113
RTL-cap	Plastic caps for the SOLO200 Detector Removal Tool (scope of delivery = 2 pieces)	4.998.082.502
FME-420-ADAP	Tool Adapter for MS 420	F.01U.510.318
SOLO330	Smoke Detector Tester	4.998.112.071

<b>Type number</b>	<b>Designation</b>	<b>Product ID</b>
FME-TEST-SMOKE	Test Aerosol for Optical Smoke Detectors (250 ml, 1 delivery pack = 12 pieces)	F.01U.301.104
FME-TEST-CO	CO Testing gas (400 ml, 1 delivery pack = 12 pieces)	F.01U.301.469
SOLO461	Heat Detector Tester	4.998.112.072
SOLO720	Battery for SOLO461 Heat Detector Tester	4.998.147.576
FME-TESTIFIRE	Multi-Stimulus Testing Tool	F.01U.143.407
FME-TS3	Smoke Capsule	F.01U.143.404
FME-TC3	CO-Capsule	F.01U.143.405
SOLO100	Telescopic Access Pole	4.998.112.069
SOLO101	Fixed Extension Pole	4.998.112.070
SOLO610	Test Equipment Bag	4.998.112.073

## 7 Maintenance and Service

In Germany, maintenance work and inspection work on security systems are governed by the regulations of DIN VDE 0833; these regulations stipulate reference to the manufacturer's instructions for maintenance intervals.

- Maintenance and inspection work should be carried out regularly and by trained personnel.
- BOSCH ST recommends carrying out a functional and visual inspection at least once a year.

Testing	Detector Type			
	FAP-425-DO-R, FAP-425-O-R, FAP-425-O	FAH-425-T-R	FAP-425-DOT-R, FAP-425-OT-R, FAP-425-OT	FAP-425-DOTC-R
Check of the LED display	X	X	X	X
Visual check of the mounting	X	X	X	X
Visual check for damage	X	X	X	X
Check the monitoring range has not been restricted, for instance by shelves or similar installations.	X	X	X	X
Triggering with hot air	-	X	X	X
Triggering with Test Aerosol	X	-	X	X
Triggering with CO Testing gas	-	-	-	X

- With the FAP-425-DOTC-R, the gas sensor has a life cycle of max. 6 years. Once the gas sensor has been switched off, this detector continues to function as a DOT or DO detector and is displayed on the panel with "EMERGENCY OPERATION".

**This is why multisensor detectors with C sensors need to be exchanged every 5-6 years.**

- Optical fire detectors should, depending on the environmental conditions, be cleaned and exchanged regularly.

In especially dusty environments, cleaning and exchange may be necessary earlier.

Every detector has a Chamber Maid Plug (cleaning opening with a plug) for blowing out the optical chamber with compressed air (not required for the Heat Detector).

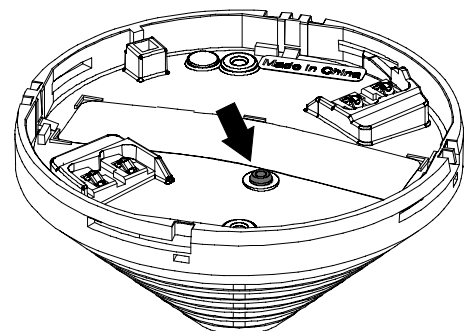

### 7.1 Detector Type Encoding

With the exception of the FAP-425-O-R and FAP-425-O, all detectors are fitted with a colored ring around the central individual display to identify the detector type.

This facilitates inspection by service personnel.

Type number	Color code	
FAP-425-DOTC-R	2 x yellow	
FAP-425-DOT-R	2 x black	
FAP-425-OT-R / FAP-425-OT	Black	
FAH-425-T-R	Red	
FAP-425-DO-R	2 x gray	
FAP-425-O-R / FAP-425-O	-	

## 7.2 Test Instructions for LSN improved version Fire Detectors

The latest generation of FAP-425-DOTC-R Multisensor Detectors is equipped with an additional sensor for detecting CO in the event of a fire. The CO sensor provides improved response behavior and increased malfunction suppression in critical environmental conditions. For fire detection, detectors use the time behavior of the fire characteristics, which deviates significantly from the time behavior of disturbance variables and also from the time behavior of a detector check with aerosol.

Therefore, for a functional test, the detector must be switched to revision mode.

### 7.2.1 Test Instructions for All Fire Detectors With Optical Sensor

- On the fire panel, switch the detector zone to be inspected to revision mode. Thus the detector is set automatically into revision operation and prepared for the detector test.
- Only in walktest mode can the detector’s individual sensors be made to trigger one after the other with the corresponding test device. For this, you should use the service accessories we recommend.
- The optical sensor is tested with the detector tester for smoke detectors with the test aerosol.



#### Notice!

The test head must remain over the detector until the detector has been triggered. The distribution of the test aerosol in the transceiver and thus the trigger time of the sensor can take up to 10 seconds.

#### Testing outside the Revision Mode

If you want to test detectors in controls, 2-detector or 2-goup dependencies, you must test them outside the revision mode. Proceed as follows:

- FAP-425-O-R, FAP-425-O and FAP-425-DO-R Trigger the detector with a testing aerosol. Depending on the sensitivity settings, it can take up to 1 minute till the detector activates. It is recommended to apply the aerosol in spurts (for example one short spurt of 1 second, 30 seconds of waiting, another short spurt).
- All other detector variants: Trigger the T-piece.

## 7.2.2

### Test Instructions for FAP-425-DOTC-R / FAP-425-DOT-R / FAP-425-OT-R / FAP-425-OT

#### Sequential walktest

Select walktest type "Sequential walktest" on the FPA-5000/FPA-1200 panel controller in the walktest menu.

- The same test device is used to test the CO sensor in the FAP-425-DOTC-R. You only need to exchange the test aerosol with the CO testing gas bottle. The testing gas must be applied for 1/2 to 1 second for the CO test.



#### Notice!

The test head must remain over the detector until the detector has been triggered. The time taken to distribute the test aerosol in the test head and therefore the trigger time of the sensor can be up to 20 seconds.

- The thermal sensor of the FAP-425-DOTC-R / FAP-425-DOT-R / FAP-425-OT-R / FAP-425-OT is tested with the test device for heat detectors.

#### Simultaneous walktest

Select walktest type "Simultaneous Walktest" on the the FPA-5000/FPA-1200 panel controller in the walktest menu.

Multisensor detectors can be tested simultaneously with the FME-TESTIFIRE multi-stimulus test tool. Observe the notes in the detector testing device and fire panel operating instructions.



#### Notice!

An alarm message is only displayed on the panel if all sensors are triggered during the simultaneous walktest. If this does not happen, one of the sensors is faulty.

#### Testing outside the Revision Mode

The FAP-425-DOTC-R detector can be triggered outside of the revision mode only by the following stimuli:

- Rise of temperature according to the sensitivity settings A2R, A2S, BR, and BS as defined by EN 54-5
- Simultaneous creation of artificial smoke and CO (by a suitable multi-stimulus test tool, like FME-TESTIFIRE)
- Simultaneous creation of artificial smoke and rise of temperature (by a suitable multi-stimulus test tool, like FME-TESTIFIRE)

## 7.3

### Diagnostic Data

- Module Address

Module where the detector or detector line is installed.

- Address

Detector installation address, e.g. 10-03: The detector is in zone 10 and is the detector number 3.

- Brief Info

Additional information entered during programming. You can also enter the position of the detector here.

- Type

Detector type

- Serial number



The first digit of the 8-digit serial number represents the year of manufacturing.

- Current analog values

Optical system value:

Optical system value (display of the current contamination value)	
0 ... 170	Initial set-up value for a new detector
0 ... 350	Normal working range
350 ... 450	Slight contamination: Exchange detector soon
450 ... 510	Heavy contamination: Exchange detector immediately
>511	O fault: optical sensor is deactivated!

Temperature value:

Temperature value [°C] (display of the value currently being measured by the thermal sensor):	
FAH-425-T-R, FAP-425-OT-R, FAP-425-OT, FAP-425-DOT-R	-20 °C ... +50 °C
FAP-425-DOTC-R	-10 °C... +50 °C

CO value:

Display of the value currently being measured by the CO sensor

The CO value specifies the currently-measured CO concentration. The specified number is calculated as the difference between the current measurement value and the stand-by value stored in the detector. The CO concentration displayed lies in the range between 0 (normal operating condition) and 555 (max. measurement value of the sensor).

EMC value:

Indicates EMC level. There is a current EMC value (short-term measurement) used during/right after installation of the detector and average EMC value (long-term measurement) used during operation of the detector.

Current EMC value	Average EMC value	Description
0...8	0...49	Low EMC level. No action required.
9...20	50...79	Medium EMC level. Consider location.
>20	80...100	High EMC level. No suitable location.

- Operating hours counter

Operating hours starting from the initial start-up of the detector.

- Error code C malfunction

Error code	Cause of trouble and troubleshooting
10000000	General C malfunction Possible causes: – – Thermal sensor fault – – Maximum operation duration (5 years) of the C sensor has been exceeded. T and C sensors are switched off; the optical sensor is still in operation. Exchange detector immediately.
11000000	The impedance of the electrochemical cell is too high. The C sensor is switched off; the rest of the sensors are still in operation. Exchange detector immediately.
10100000	The permissible operating temperature (-10 °C to +50 °C) has been exceeded. The C sensor is switched off; the rest of the sensors are still in operation.
10011110	Malfunction due to read/write error in the EEPROM Detector is switched off and must be exchanged immediately.
0000xxxx	Number of read/write errors in the EEPROM

- Contamination

The optical initial set-up value of a new detector is stored in the integrated EEPROM during the final inspection. The contamination value specifies by how much this analog value has increased in comparison with the delivery state.

## 7.4 Warranty

Defective detectors are exchanged free of charge in the case of a claim under the warranty.

## 7.5 Repair

In the event of a defect, exchange the entire detector.

## 7.6 Disposal

Unusable electrical and electronic devices or modules must not be disposed of with normal household refuse. They must be disposed of in compliance with the applicable regulations and directives (e.g. WEEE in Europe).



### Packaging film for the FAP-425-DOTC-R

The packaging bag used for multisensor detectors with C sensor consists of tear-resistant PE-ALU laminated film and may be disposed of with the household refuse.

**Defective detectors are exchanged and should be disposed of in accordance with legal regulations.**

## 8 Technical Data

### Detector overview

	FAP-425-DOTC-R	FAP-425-DOT-R	FAP-425-DO-R	FAP-425-OT-R	FAP-425-O-R	FAH-425-T-R
Scattered-light measurement	X	X	X	X	-	-
Measurement of absolute temperature and temperature increase	X	X	-	X	-	X
Combustion gas measurement	X	-	-	-	-	-
Two optical sensors	X	X	X	-	-	-
Contamination detection	X	X	X	X	X	-
Drift comparison in the optical sensor	X	X	X	X	X	-
Operation mode switching/sensor deactivation in optical unit and thermal unit	X	X	-	X	-	-
Operating voltage	15 V DC to 33 V DC					
Current consumption	< 0.55 mA					
Individual display	Two-color LED (red/green)					
Alarm output	Per data word by two-wire signal line					
Indicator output	Open collector connects 0 V over 1.5 kΩ , max 15 mA					
Response sensitivity (default settings with medium sensitivity, adjustable to different sensitivity levels)						
Optical sensor	Average < 0.15 dB/m (EN 54-7) Max.< 0.18 dB/m (EN 54-7)					
Thermal differential unit	EN 54-5	EN 54-5	-	EN 54-5	-	EN 54-5
Thermal maximum unit	> 54 °C / > 69 °C	> 54 °C / > 69 °C	-	> 54 °C / > 69 °C	-	> 54 °C / > 69 °C
Chemical Sensor	ppm range	-	-	-	-	-
Max. monitoring area (observe VdS guidelines)	120 m <sup>2</sup>					40m <sup>2</sup>

	FAP-425-DOTC-R	FAP-425-DOT-R	FAP-425-DO-R	FAP-425-OT-R	FAP-425-O-R	FAH-425-T-R
Max. installation height (observe VdS guidelines)	16 m					7.5 m
Max. permitted air speed	20 m/s					-
Min. permitted storage temperature	-20 °C	-25 °C				
Max. permitted storage temperature	+50 °C	+80 °C				
Min. permitted operating temperature	-10 °C	-20 °C				
Max. permitted operating temperature	+50 °C		+65 °C	+50 °C		+65 °C
Permitted relative humidity	< 95 % (non condensing)					
Protecting category according to EN 60529	IP 40 / IP 43 with detector base with damp room seal					
Ring color code	2x yellow	2x black	2x grey	1x black	-	1x red
Dimensions without base	ø 99.5 mm x 52 mm					
Dimensions with base	ø 120 mm x 63.5 mm					
Housing material/color	ABS/white, similar to RAL 9010, matte surface					
Approx. weight without packaging	80 g	75 g				
Approx. weight with packaging	135 g	125 g		115 g		
Product ID	F.01U. 280.451	F.01U. 279.989	F.01U. 279.988	F.01U. 280.245	F.01U. 280.244	F.01U. 280.243

The FAP-425-O and the FAP-425-OT have the same technical data as the FAP-425-O-R and FAP-425-OT-R, but are not fitted with rotary switches.



**Bosch Sicherheitssysteme GmbH**

Robert-Bosch-Ring 5

85630 Grasbrunn

Germany

**[www.boschsecurity.com](http://www.boschsecurity.com)**

© Bosch Sicherheitssysteme GmbH, 2014