

NTM

HOUSING FOR THERMAL CAMERAS IN HOSTILE ENVIRONMENTS

MAIN FEATURES

Made of AISI 316L electropolished stainless steel

Germanium window

Cylindrical body enclosed by two 9mm(0.4in)-thick circular flanges

2 PG13,5 cable glands nickel-plated brass for external connections

IP66/IP67

Available accessories: camera power supply

DESCRIPTION

This housing for thermal camera provides the vision also in complete darkness, fog, rain, smoke or for long-range distances.

The germanium window has non-scratch treated, Hard Carbon Coating (DLC) on the outside and antireflection inside; the spectral range is from 7.5 to 14 μ m.

The AISI 316L stainless steel construction allows the installation in environments with highly corrosive external agents, such as marine, industrial or chemical environments.

The NTM housing can be installed on NXPTH Pan & Tilt head, to obtain a complete positioning system.



NTM

AVAILABLE MODELS

Model Number	Housing sunshield	Power supply 230Vac	Power supply 24Vac	Ø germanium window
NTM1K1000	✓	✓	–	55mm (2.1in)

TECHNICAL DATA

GENERAL

Constructed from electropolished stainless steel (austenitic alloy stainless steel, corrosion and heat resistant according to the following standards):

- AISI 316L
- UNI 6900-71: X 2 Cr Ni Mo 17 12 2
- DIN 17006: X 2 Cr Ni Mo 17 13 2
- N° werkstoff 1.4404
- AFNOR: Z2 CND 17-12
- BSI: 316S11

The screws utilised are in austenitic alloy stainless steel, corrosion and heat resistant according to the following standards:

- ISO: 7380
- AISI: 316
- ISO quality: A4
- Resistance class ISO: from 50 to 70

MECHANICAL

Cable glands: 2xPG13.5 (nickel-plated brass for external connections)

External body polishing

Flange thickness: 9mm (front/back)

Gaskets: High sealing O-ring

Internal usable area (WxH): 88x86mm (3.5x3.4in)

Internal usable length (without accessories): 334mm (13.1in)

Internal usable length (with heater and/or power supply): 245mm (9.6in)

Unit weight: 6kg (13.3lb)

HOUSING'S WINDOW

Material: Germanium

Dimensions:

- Diameter: 70mm (2.8in) (external), 55mm (2.1in) (internal)
- Thick: 2mm (0.07in)

External treatment: Antiscratch (Hard Carbon Coating- DLC), Antireflection

Internal treatment: Antireflection

Spectral range: from 7.5µm up to 14µm

- Medium transmittance (from 7.5µm up to 11.5µm): 90%
- Medium transmittance (from 11.5µm up to 14µm): 77%

ELECTRICAL

Heater (Ton 15°C±3°C (59°F±5°F), Toff 22°C±3°C (72°F±5°F))

- Power supply/Consumption: IN 12Vdc/24Vac, 20W max
- Power supply/Consumption: IN 120/230Vac, 40W max

Camera power supply

- IN 100-240Vac - OUT 12Vdc, 50/60Hz, 1A
- IN 230Vac - OUT 24Vac, 50/60Hz, 400mA

ENVIRONMENT

Indoor/Outdoor

Operating temperature with heating: from -20°C (-4°F) up to +60°C (140°F)

CERTIFICATIONS

Electrical safety (CE): EN60065

Electromagnetic compatibility (CE): EN50130-4, EN61000-6-3

IP protection degree: EN60529 (IP66/IP67)

EAC certification

ACCESSORIES

ONXPS1B Wide range power supply for camera IN 100-240Vac - OUT 12Vdc, 1A

ONXPS2B Camera power supply IN 230Vac - OUT 24Vac, 400mA

RELATED PRODUCTS

NXPHT Stainless steel P&T motor

BRACKETS AND ADAPTORS

NXWBS1 AISI 316L stainless steel wall bracket with joint

SPARE PARTS

ONXMMAN Maintenance kit for NXM

ONTMFA Front cover complete with germanium window

PACKAGE

Model Number	Weight	Dimensions (WxHxL)	Master carton
NTM1K1000	7.3kg (16.1in)	24.5x24.5x62cm	-

TECHNICAL DRAWINGS

Sizes in millimeters.

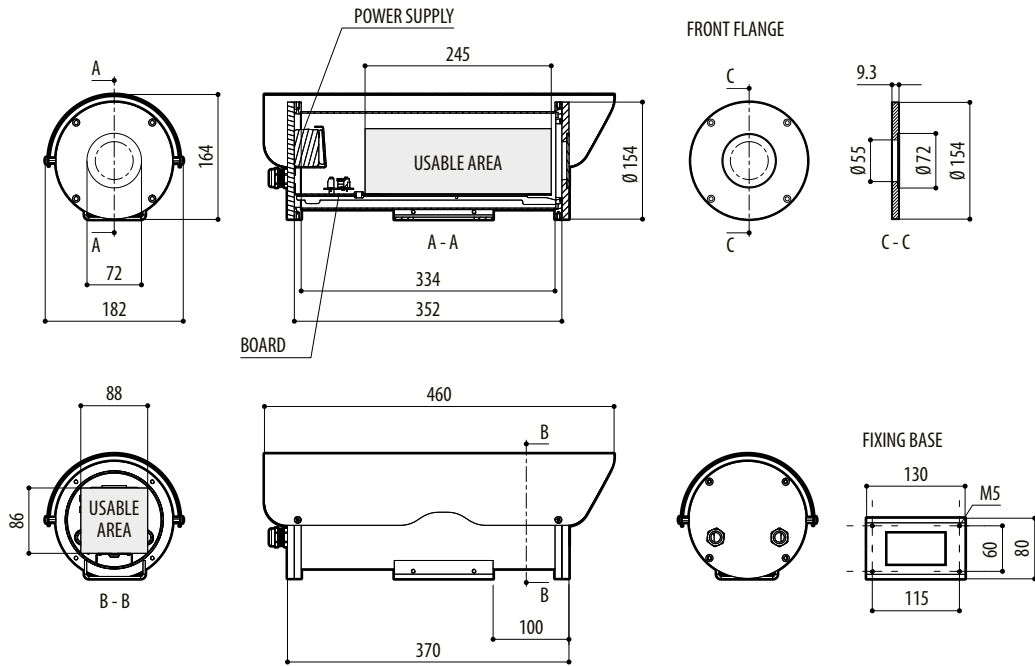

NTM