

High Resolution PTZ Dome Cameras

ZC-PT Series

INSTRUCTION MANUAL

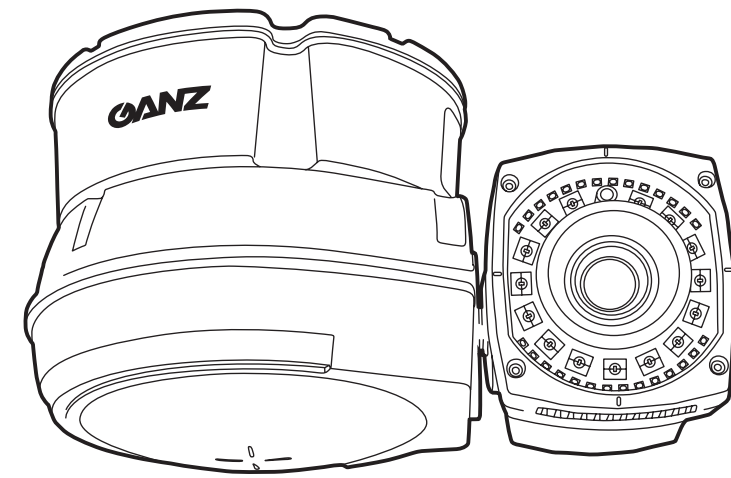

GANZ[®]

ENGLISH

Contents



ZC-PT SERIES

CONTENTS	2
COMPONENTS	2
WARNINGS & CAUTIONS	3
GENERAL FEATURES	6
PART NAMES	7
A. Basic Parts	7
B. Connection Method	8
INSTALLATION	9
A. Ceiling Mount Bracket	9
B. Pole Stand	11
C. Wall Mount Bracket	13
QUICK OPERATING KEYS	15
DIAGNOSTIC	17
OSD MENU SETTING	18
A. OSD Menu Table	18
B. Dome Set	19
C. Camera Set	25
D. Preset Set	27
E. Auto Scan Set	28
F. Tour Set	29
G. Privacy Set	31
H. Pattern Set	32
I. Alarm Set	33
J. Sector Set	34
DIP SWITCHING SETTING	35
A. ID Setting	35
B. 485 Termination	41
C. Protocol	41
D. Baud Rate Setting	41
TROUBLESHOOTING	42
SPECIFICATION	43
DIMENSIONS	44

Components



ZC-PT SERIES

1. IR CAMERA 1SET

2. MANUAL 1EA

Warnings & Cautions



ZC-PT SERIES

- If you fail to read this information and handle the product incorrectly, death or serious injury may occur.
- The unit should be installed by the trained personnel.
- Switch off immediately if the product emits smoke or abnormal heat.
- Never install the product in area exposed to oil or gas.
- Never touch the power cord with wet hands.
- Clean only with dry cloth.
- Ensure that the product is not subjected to strong impacts and vibration.



CAUTION

RISK OF ELECTRIC SHOCK
DO NOT OPEN



CAUTION: TO REDUCE THE RISK OF ELECTRIC SHOCK,
DO NOT REMOVE COVER (OR BACK)
NO USER SERVICEABLE PARTS INSIDE.
REFER SERVICING TO QUALIFIED SERVICE PERSONNEL.



This symbol is intended to alert the user to the presence of un-insulated "dangerous voltage" within the product's enclosure that may be of sufficient magnitude to constitute a risk of electric shock to persons.



This symbol is intended to alert the user to the presence of un-insulated "dangerous voltage" within the product's enclosure that may be of sufficient magnitude to constitute a risk of electric shock to persons.

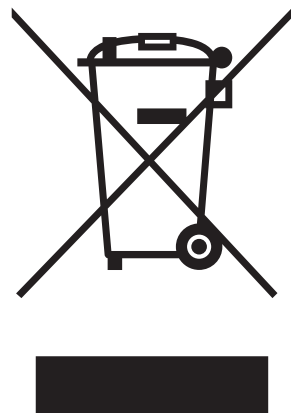

English Disposal of your old appliance

1. When this crossed-out wheeled bin symbol is attached to a product it means the product is covered by the European Directive 2002/96/EC.
2. All electrical and electronic products should be disposed of separately from the municipal waste stream via designated collection facilities appointed by the government or the local authorities.
3. The correct disposal of your old appliance will help prevent potential negative consequences for the environment and human health.
4. For more detailed information about disposal of your old appliance, please contact your city office, waste disposal service or the shop where you purchased the product.

Français/French Élimination de votre ancien appareil

1. Ce symbole, représentant une poubelle sur roulettes barrée d'une croix, signifie que le produit est couvert par la directive européenne 2002/96/EC.
2. Tous les produits électriques et électroniques doivent être éliminés séparément de la chaîne de collecte municipale des ordures, par l'intermédiaire des installations de collecte prescrites et désignées par le gouvernement ou les autorités locales.
3. Une élimination conforme aux instructions aidera à réduire les conséquences négatives et risques éventuels pour l'environnement et la santé humaine.
4. Pour plus d'informations concernant l'élimination de votre ancien appareil, veuillez contacter votre mairie, le service des ordures ménagères ou encore le magasin où vous avez acheté ce produit.

Deutsch/German Entsorgung von Altgeräten

1. Wenn dieses Symbol eines durchgestrichenen Abfalleimers auf einem Produkt angebracht ist, unterliegt dieses Produkt der europäischen Richtlinie 2002/96/EC.
2. Alle Elektro- und Elektronik-Altgeräte müssen getrennt vom Hausmüll über die dafür staatlich vorgesehenen Stellen entsorgt werden.
3. Mit der ordnungsgemäßen Entsorgung des alten Geräts vermeiden Sie Umweltschäden und eine Gefährdung der persönlichen Gesundheit.
4. Weitere Informationen zur Entsorgung des alten Geräts erhalten Sie bei der Stadtverwaltung, beim Entsorgungsamt oder in dem Geschäft, wo Sie das Produkt erworben haben.



Italiano/Italian RAEE: SMALTIMENTO DELLE VOSTRE VECCHIE APPARECCHIATURE

1. Quando il simbolo del "Cassonetto Barrato" è apposto su un prodotto, significa che lo stesso può ricadere nei termini previsti dalla Direttiva Europea nr. 2002/96/EC in funzione dell'attuazione definita dalla Legislazione dei singoli stati membri dell'Unione Europea.
2. Tutti i prodotti elettrici ed elettronici dovrebbero essere smaltiti separatamente dai rifiuti municipali, tramite appositi contenitori, approvati dall'Amministrazione Comunale o dalle Autorità Locali.
3. Il corretto smaltimento delle vostre vecchie apparecchiature, contribuirà a prevenire possibili conseguenze di impatto negativo sull'ambiente e per la salute dell'uomo.
4. Per maggiori informazioni circa lo smaltimento delle vostre vecchie apparecchiature, siete pregati di contattare l'ufficio municipale della vostra città, il servizio di smaltimento rifiuti o il punto vendita nel quale avete acquistato il prodotto.

Polski/Polish Utylizacja starych urządzeń

1. Kiedy do produktu dołączony jest niniejszy przekreślony symbol kołowego pojemnika na śmieci, oznacza to, że produkt jest objęty europejską dyrektywą 2002/96/EC.
2. Wszystkie elektryczne i elektroniczne produkty powinny być utylizowane niezależnie od odpadów miejskich, z wykorzystaniem przeznaczonych do tego miejsc składowania wskazanych przez rząd lub miejscowe władze.
3. Właściwy sposób utylizacji starego urządzenia pomoże zapobiec potencjalnie negatywnemu wpływowi na zdrowie i środowisko.
4. Aby uzyskać więcej informacji o sposobach utylizacji starych urządzeń, należy skontaktować się z władzami lokalnymi, przedsiębiorstwem

zajmującym się utylizacją odpadów lub sklepem, w którym produkt został kupiony.

Português/Portuguese Eliminação do seu antigo aparelho

1. Quando este símbolo de latão cruzado estiver afixado a um produto, significa que o produto é abrangido pela Directiva Europeia 2002/96/EC.
2. Todos os produtos eléctricos e electrónicos devem ser eliminados separadamente da coleta de lixo municipal através de pontos de recolha designados, facilitados pelo governo ou autoridades locais.
3. A eliminação correcta do seu aparelho antigo ajuda a evitar potenciais consequências negativas para o ambiente e para a saúde humana.
4. Para obter informações mais detalhadas acerca da eliminação do seu aparelho antigo, contacte as autoridades locais, um serviço de eliminação de resíduos ou a loja onde comprou o produto.

Español/Spanish Cómo deshacerse de aparatos eléctricos y electrónicos viejos

1. Si en un producto aparece el símbolo de un contenedor de basura tachado, significa que éste se acoge a la Directiva 2002/96/EC.
2. Todos los aparatos eléctricos o electrónicos se deben desechar de forma distinta del servicio municipal de recogida de basura, a través de puntos de recogida designados por el gobierno o las autoridades locales.
3. La correcta recogida y tratamiento de los dispositivos inservibles contribuye a evitar riesgos potenciales para el medio ambiente y la salud pública.
4. Para obtener más información sobre cómo deshacerse de sus aparatos eléctricos y electrónicos viejos, póngase en contacto con su ayuntamiento, el servicio de recogida de basuras o el establecimiento donde adquirió el producto.

General Features



ZC-PT SERIES

- IR LED PTZ has been designed unique and strong with high quality for security applications that demand the very high performance both day and at night time.
- The range offers numerous benefits over the use of traditional dome and PTZ cameras, and comes with a variety of options in order to offer a best fit solution for virtually any application.
- Rated to an industry leading IP68, the vandal resistant aluminum camera housing is suitable for installation in the harshest of environments.
- Surveillance with optimum picture is possible owing to filter changeable Day & Night function and DSS function.
- Auto-IR cut filter removable function is the auto-controlling operation such as color picture plus infrared cut filter during the day and black and white picture plus filter elimination at night.

THE WORLD'S FIRST 360° ENDLESS PAN/TILT MOTION

- IR PTZ camera adopted the world's first 360° endless Pan / Tilt.

AUTO LED BRIGHTNESS CONTROL BY DISTANCE RANGE

- When it's on a wide angle(zoom out), illumination level of LED is automatically readjusted to a dimmer level by way of prevention against image saturation. When it's on a narrow angle(zoom in), illumination level of LED is automatically readjusted to get the maximum to have enough light for clear image display and reduction of energy consumption (30° LED 28EA, 12° LED 15EA)

PAN / TILT TORQUE COMPENSATION

- Pan / Tilt Torque vibration sensor keeps the Pan / Tilt Motor securely in place during strong winds.

AUTO LED PULSE CONTROL BY DISTANCE RANGE

- It automatically controls the pulse of LED electric current which is consumed Most depending on distance range so that it produces 2 times better LED Brightness with same amount of electric current as others.

Part Names

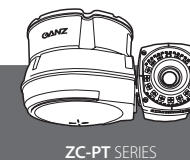

ZC-PT SERIES

A. Basic Parts

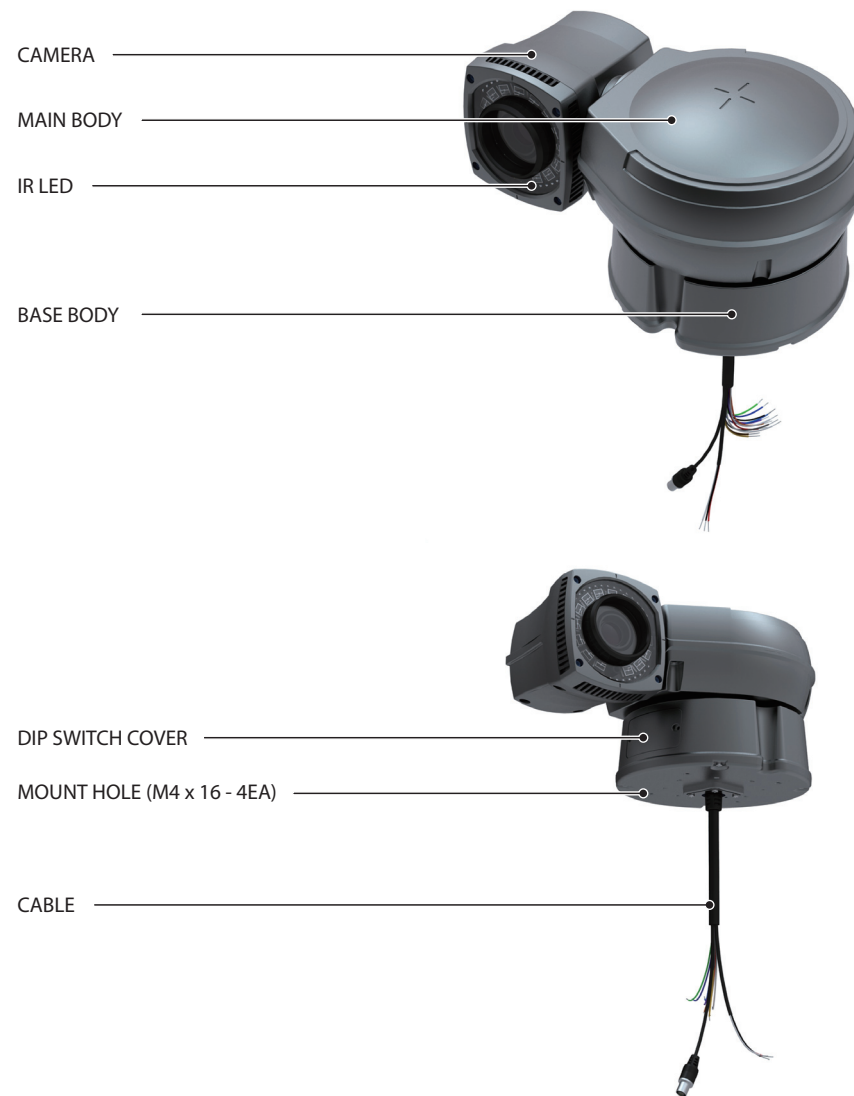

Part Names



ZC-PT SERIES

B. Connection Method



a) Explanation

Color	USE
BLACK	BNC Video Cable

b) Explanation

Color	USE
YELLOW	AUX 1-A
BROWN	AUX 1-B
RED	AUX 2-A
WHITE	AUX 2-B
GRAY	GND
VIRMLION (ORANGE)	ALARM 1
VIOLET	ALARM 2
PINK	ALARM 3
SKY BLUE	ALARM 4
BLACK	GND
BLUE	RS-485 D+
GREEN	RS-485 D-

(AWG#20)

c) Explanation

Color	USE
RED	AC 24
WHITE	AC 24
BLACK	F. G.

Installation



ZC-PT SERIES

A. Ceiling Mount Bracket

CONTENTS

1. CEILING MOUNT BRACKET	1EA	4. SPRING WASHER Ø4	5EA
2. SET ANCHOR BOLT (W5/9)	4EA	5. WRENCH (3mm)	4EA
3. SCREW M4 x 16	5EA	6. MANUAL	

A-1. When you install IR PTZ Camera on the ceiling, make 4 holes at the edge with Ø13 in diameter and 37mm in depth. If you want to connect the cables from the inside of the ceiling, also make a hole for the cables with about Ø30~50 in diameter in the center of 4 edges. (FIG.1)

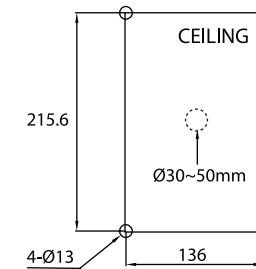

FIG.1

A-2. Connect the Ceiling Mount Bracket to the Camera with 4 pieces of M4X16 screws and spring washer. (FIG.2)

A-3. Connect the Safety wire of the Camera to the Bracket. In order to avoid getting entangled in the Camera, fasten the Safety wire to the bracket with Cable tie. (FIG.3)

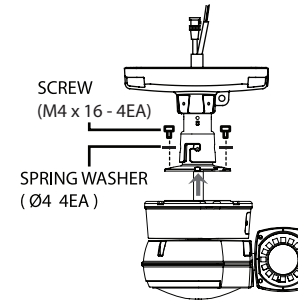

FIG.2

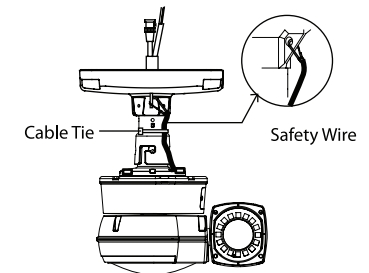
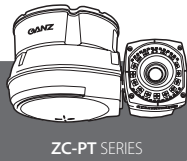

FIG.3

Installation



ZC-PT SERIES

A-4. When you want to connect the cables from the inside of ceiling, pass the cables through the ceiling. When you want to connect the cables from the outside of ceiling, remove the hole cap from the side of the bracket and pass the cables through the hole.

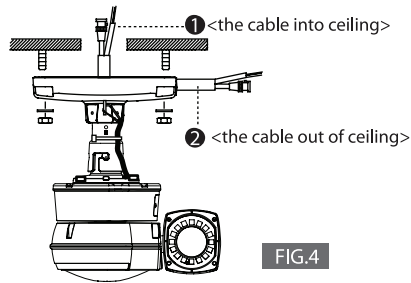

FIG.4

A-5. Install 4 pieces of Anchor bolt in the holes at the edge and tight enough with Nuts. (FIG.4)

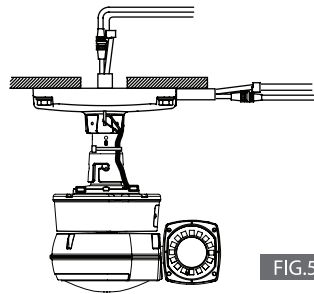
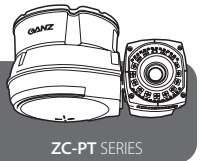

FIG.5

A-6. Connect the cables referring to the page 8. (FIG.5)

Installation



ZC-PT SERIES

B. Pole Stand

CONTENTS

1. POLE STAND	1EA	6. SCREW M4 x 16	5EA
2. BOLT M10 x 45	4EA	7. SPRING WAHGER Ø4	5EA
3. NUT M10	4EA	8. WRENCH (3mm)	1EA
4. FLAT WASHER	4EA	9. MANUAL	
5. SPRING WASHER Ø10	4EA		

B-1. When you install IR-PTZ Camera on the pole, make 4 holes at edge with $\text{Ø}13$ in diameter and 37mm in depth. Make also a hole for the cables with about $\text{Ø}30\sim 50$ in diameter in the bottom center of the bracket. (FIG.6)

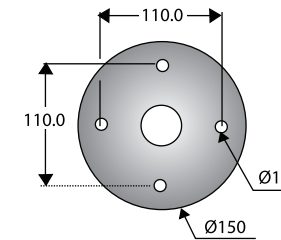

FIG.6

B-2. Pass the cables of the camera through the inside of Pole Stand and connect the Camera to the Pole Stand with pieces of M4*16 screws. (FIG.7)

B-3. Connect the Safety Wire of the camera to the bracket. In order to avoid getting entangled in the camera, fasten the Safety wire to the bracket with Cable Tie. (FIG.8)

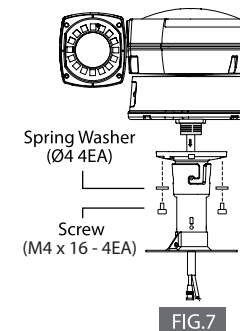

FIG.7

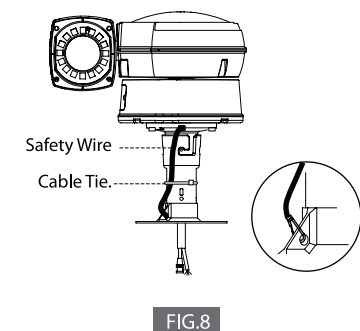

FIG.8

Installation



ZC-PT SERIES

B-4. Install 4 pieces of Anchor bolt in the $\varnothing 13$ holes at the edge and connect the cables.

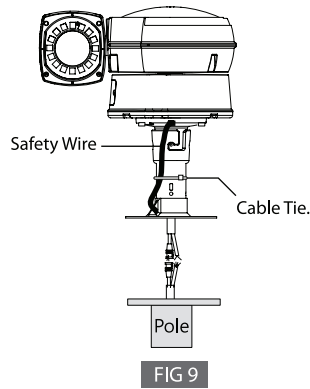

FIG. 9

B-5. Adjust the Camera and Pole Stand to M10 x 45 Bolt and Flat Washer, Spring Washer. And then tight enough with Nuts. (FIG.10)

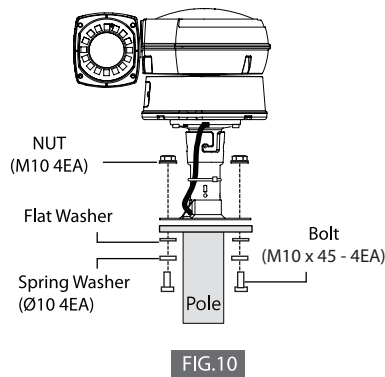
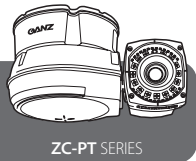

FIG.10

Installation



ZC-PT SERIES

C. Wall Mount Bracket

CONTENTS

1. WALL MOUNT BRACKET	1EA	4. SPRING WASHER $\varnothing 4$	5EA
2. SET ANCHOR BOLT (W5/6)	4EA	5. WRENCH (3mm)	1EA
3. SCREW M4 x 16	5EA	6. MANUAL	

C-1. When you install IR PTZ Camera on the wall, make 4 holes at the edge with $\varnothing 13$ in diameter and 37mm in depth and install 4 pieces of Anchor bolt in the $\varnothing 13$ holes at the edge. (FIG.11)

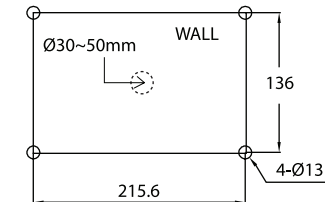

FIG.11

- If you want to connect the cables from the inside of the wall, also ake a hole for the cables with about $\varnothing 30\sim 50$ in diameter in the center of 4 edges.
- In order to avoid the impact of the Camera and Bracket when moving, set and drill in the long side as length and the short side as height.
- Check also if the long side of the Bracket sets as length and the short side of the Bracket sets as height.

C-2. Connect the Camera to Wall Mount Bracket with 4 pieces of M4 x 16 screws and Spring Washer. (FIG.12)

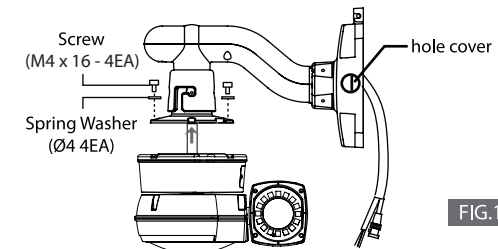

FIG.12



Installation

C-3. Connect the Safety wire of the Camera to the Bracket. In order to avoid getting entangled in the Camera, fasten the Safety wire to the bracket with Cable tie. (FIG.13)

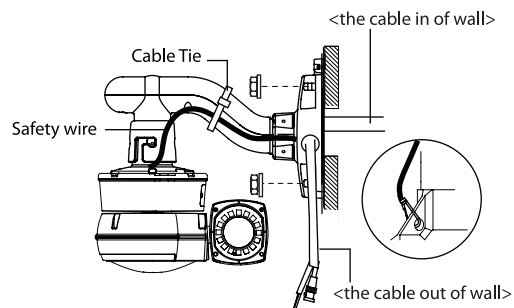

FIG.13

C-4. When you want to connect the cables from the inside of wall, pass the cables through the wall. When you want to connect the cables from the outside of wall, remove the hole cap from the side of the bracket and pass the cables through the hole.

C-5. Install 4 pieces of Anchor bolt in the holes at the edge and tight enough with Nuts. (FIG. 13)

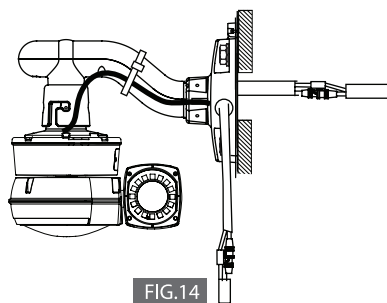

FIG.14

C-6. Connect the cables referring to the page 8. (FIG.14)



Quick Operating Keys

The IR Camera supports Pelco D/P Protocols
The default setting of the IR Camera is Pelco D/P(Auto Detection) with 2400bps (Baud rate).

[PELCO D/P PROTOCOLS]

The comprehensive feature set of the camera is available from Pelco Compatible controllers via quick operation keys as defined below.

1 ~ 64 + preset and 100 ~ 200 + preset are used for normal user presets.

Presets 65 ~ 99 + are reserved for special functions.

For Example, to enter OSD MENU, press the button 95 + Preset.

<Quick Operation Key Table 1>

Number	Note	Function
1 ~ 64, 100 ~ 200 + PRESET	Preset	Executing Preset 1~64, 100~200
65 + PRESET	Preset Status	Display Preset Status
66 + PRESET	Auto Scan	Executing Auto Scan
70 + PRESET	VIB CORR	Selectable On/Off in picture Stabilization Function
71 ~ 78 + PRESET	Group Tour	Executing Group Tour #1~#8
81 ~ 88 + PRESET	Pattern	Executing Pattern #1~8
91 + PRESET	Zero Position	Searching Pan / Tilt Zero Position
92 + PRESET	Freeze	Select Freeze image when camera is working
93 + PRESET	BLC	Selectable On/Off BLC function
94 + PRESET	Day/Night	Selectable Day/Night/Auto Mode
95 + PRESET	OSD	Entering OSD Main Menu
96 + PRESET	Focus Adjust	Focus adjust
97 + PRESET	Alarm	Selectable Enable / Disable all alarms
98 + PRESET	AUX1	Selectable On / Off Aux1
99 + PRESET	AUX2	Selectable On / Off Aux2

<Quick Operation Key Table 2>

Number	Function
1 ~ 64, 100 ~ 200 + PRESET	Sub menu cursor moves up/down
65 + PRESET	Enter to the sub menu or status change or decrement
66 + PRESET	Using for enter key when user select YES or NO
70 + PRESET	Using for function changing keys when set coordinate
71 ~ 78 + PRESET	Status cursor to the right
81 ~ 88 + PRESET	Status cursor to the left

Quick Operating Keys



ZC-PT SERIES

• **65 + Preset**

Preset Status is displayed, to remove this screen, Press Focus Near button.

• **92 + Preset**

This feature freezes the current live image during tour, auto scan or pattern operation.

When you press 92+Preset button, the image freezes but the camera is still working as operation such as tour, pattern or auto scan.

To return to normal images, press 92+Preset button again

• This feature is operated by preset number but not included in OSD main menu.

• Due to Zoom camera module. OSD Menu not provides every feature. In this case, "Not available" is displayed on the monitor.

Diagnostic



ZC-PT SERIES

Whenever the IR Camera is power on, a standard diagnostic is operated.

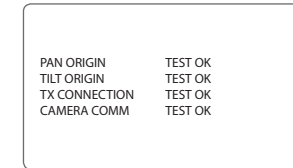
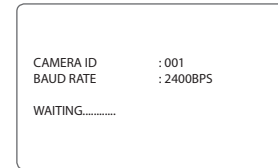

A. PAN Origin Test

Zero point of Pan is Located during the Panning test.

B. Tilt Origin Test

Zero point of Tilt is Located during the Tilt Test

C. TX Connection Test

Wait for 60 seconds for TX Connection Test.

During 60 seconds, the camera is must received a signal by any control equipment as DVR or controller.

Then OK is displayed then automatically verifying TX Connection Test

• If "Not Tested" is displayed in the test.

- The result which is not received any signal from DVR or controller
- Wrong connecting way such as the protocol, baud rate or RS-485 connection.

The use may check the install way carefully.

D. Camera Comm. Test

Camera communication is also checked.

OK should be displayed in these four tests before installation.

If all the above Tests are OK, "NOW EEPROM CHECKING" and "ALL DATA INITIALIZING" is displayed and the camera is ready to operate.



OSD Menu Setting

A. OSD Menu Table

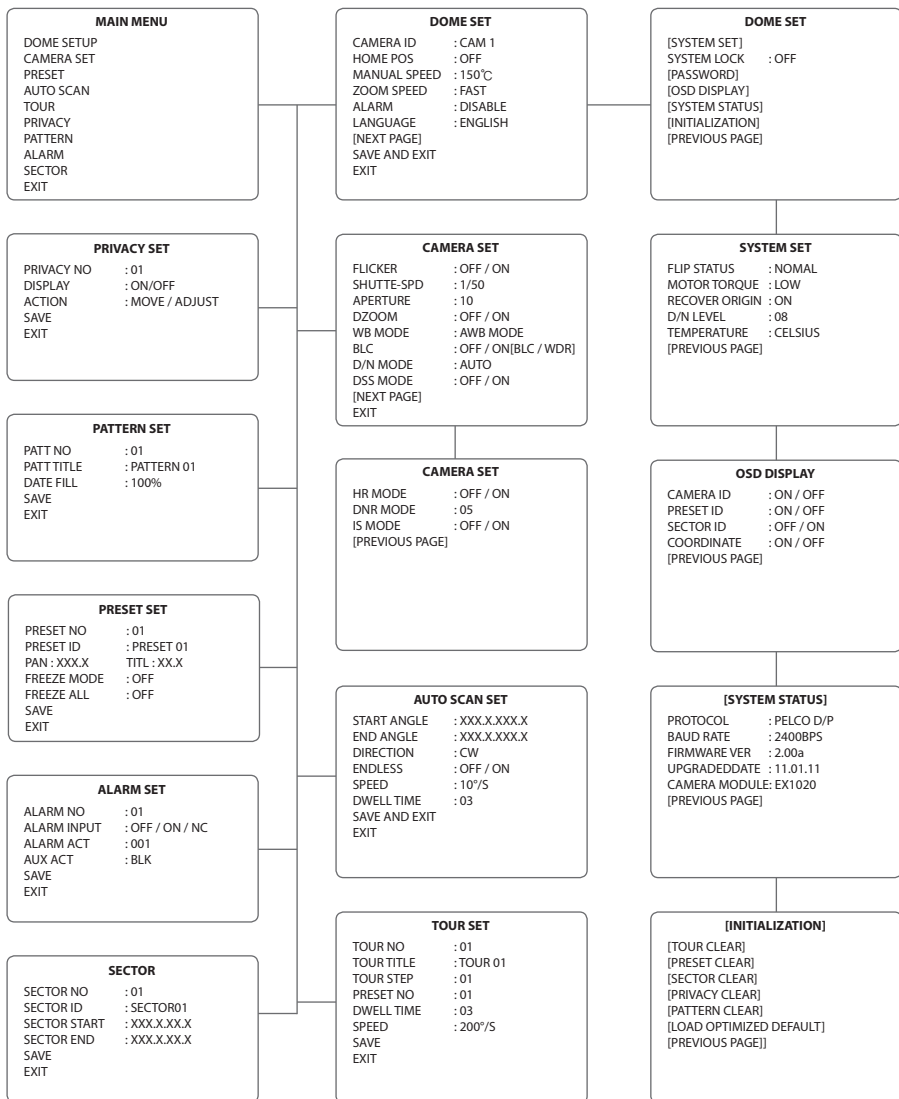

OSD Menu Setting

To enter OSD Menu, press the button 95+Preset then OSD Main Menu is displayed.

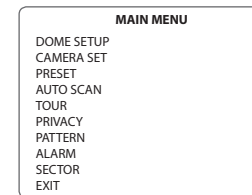

- Use the joystick up down to move the position and left right to make selection.

B. Dome Setup

To enter dome setup, use the joystick right to move when cursor on dome setup.

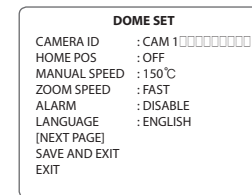

B-1. DOME SET - CAMERA ID

To set camera name, and select a title of up to 16 characters using left or right direction keys or joystick. Press ZOOM TELE button to move to the next character from left to right direction and ZOOM WIDE button to move to the next character from right to left direction. (Space displays when □ appears.)

B-2. DOME SET - HOME POS

This is for Home Position, basically, including the Recover. On ON, it would be indicated the number [Relevant function], number is for time and [Relevant function] is that what operation product will be working on. You can set up the time using the Joystick Left/Right, it should be showed up on the Left of Menu if you press the Focus Far Key. In case of "[]", possible to change into other one as you want and come out from "[]" after vanish.

OSD Menu Setting



- Set time : 15~90 (Each 5)
- Set article : [AUTO] - RECOVER operation.
[PRST1]-[PRST8] – PRESET1 ~ PRESET8 OPERATION.
[TOUR1] ~ [TOUR8] – TOUR1 ~ TOUR8 OPERATION.
[PATT1] ~ [PATT8] – PATTERN1 ~ PATTERN8 OPERATION
[SCAN] – AUTOSCAN OPERATION.

B-3. DOME SET - MANUAL SPEED

Manual speed of Pan / Tilt is selectable from 100°/sec up to 200°/sec.
The default setting is 150°/sec.

B-4. DOME SET - ZOOM SPEED

Move joystick right or left direction is selectable from 0 ~ 7.
The default setting is 7.

B-5. DOME SET - ALARM

You must enable the alarms for them to operate. The default setting is disabled.

This function can be recalled by pushing 97+preset button.

B-6. DOME SET – LANGUAGE

Multiple languages are selectable here including English, Italian and Polish.
The default setting is ENGLISH.

B-7. DOME SET - [NEXT PAGE]

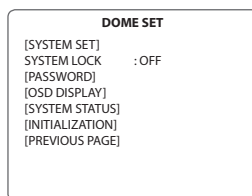

OSD Menu Setting

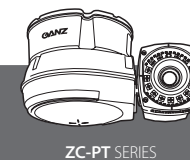

B-7-1. DOME SET - [NEXT PAGE] -SYSTEM SET

To enter system set, use the joystick right to move when cursor on system set.

- Flip status available and the default setting is NORMAL.
Move joystick right or left direction is for selecting NORMAL or REVERSE.
- Motor torque available and the default setting is LOW.
Move joystick right or left direction is for selecting LOW or MIDDLE or HIGH.
- Recover Origin is for correct when both of PAN and TILT are warped by impact.
On ON, it should be operated, on OFF, it's not.
- D/N Level is selectable 0 to 15. The default setting is 08.
- Temperature available and the default setting is CELSIUS.
Move joystick right or left direction is for selecting CELSIUS or FAHRENHEIT.

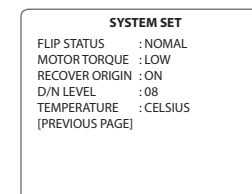

B-7-2. DOME SET - [NEXT PAGE] -SYSTEM LOCK

All stored dome settings can be password protected to prevent unauthorized changes. In order to enter [PASSWORD] page, the system lock status must firstly be set as ON. The default setting is OFF.

B-7-3. DOME SET - [NEXT PAGE] -[PASSWORD].

To enter this page to set a password. move joystick or pan key in the right direction.

The password must be set by preset number from 001 to 255 (Default 99).

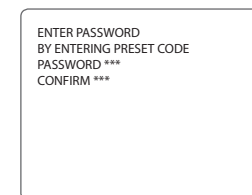

OSD Menu Setting

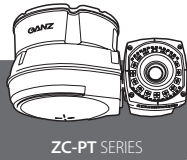

Enter any number from 001~255 on the password blank area and again on the confirm blank area.
Then "CONFIRMED" is displayed on the monitor and the menu will go back to the previous age automatically.

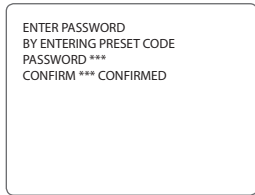

[CONFIRMED]

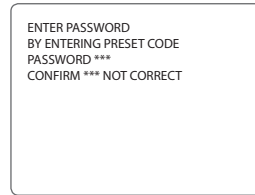

[CONFIRMED]

If you press an incorrect number between PASSWORD and CONFIRMED, "CANCELLED" is displayed on the monitor when you press FOCUS NEAR key. "CANCELLED" will be displayed on the monitor, it goes to previous page.

- When a password has been set, the operator must enter the correct password in order to enter OSD MAIN MENU, or to change any of the domes configuration data.
- If you set a password you must ensure that it does not get lost. If this happens the dome must be returned for workshop repair.

B-7-4. DOME SET - [NEXT PAGE] - [OSD DISPLAY]

The camera ID setting defines whether the camera OSD display is displayed or switched off.

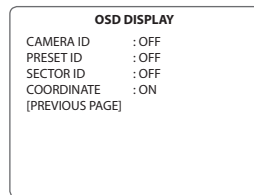

B-7-5. DOME SET - [NEXT PAGE] - [SYSTEM STATUS]

This page shows the information of this camera.

- Protocol and baud rate are shown due to the dip switch setting
- Firmware version and upgraded date will change if upgraded.
- Camera module is setting as follows.

OSD Menu Setting

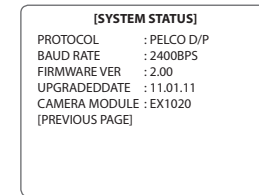
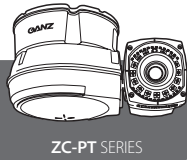

B-7-6. DOME SET - [NEXT PAGE] - [INITIALIZATION]

To clear the current settings select the item that you wish to reset back to factory defaults.

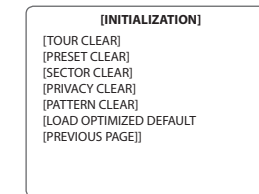

To clear the memorized data. move the joystick or pan right key until the cursor is on the required item.

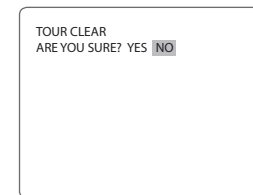

Press FOCUS NEAR button when the cursor is at YES in order to clear memorized data.

Then each item such as tour, preset, and sector will flicker for about 2 ~ 3 seconds.

After this process, the menu is returned to the previous page.

- Use the above method for [PRESET CLEAR], [SECTOR CLEAR],[PRIVACY CLEAR], [PATTERN CLEAR].

OSD Menu Setting



ZC-PT SERIES

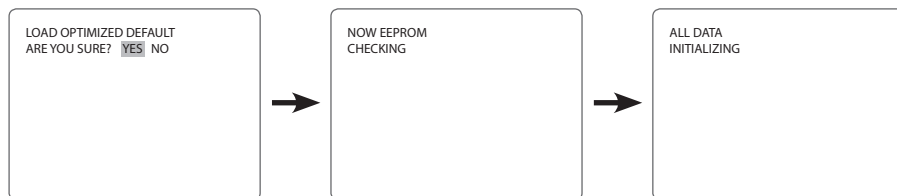

- To Clear all data and return to factory defaults, move the joystick right or press the pan light key to when the cursor is at [LOAD OPTIMIZED DEFAULT] to enter the next page.

- Move joystick or the pan right key so that the cursor is over YES, then press the FOCUS NEAR button.

“ALL DATA INITIALIZING” is then displayed for about 5~7 seconds and then the menu is returned to the previous page automatically.

B-8. DOME SET - [NEXT PAGE] - SAVE AND EXIT

To saving the memorized data and escape this page, move joystick to the right direction when cursor is at SAVE AND EXIT.

B-9. DOME SET - [NEXT PAGE] – EXIT

In order not to save any data and wants to escape this page, move joystick to the right direction when cursor is at EXIT.

OSD Menu Setting

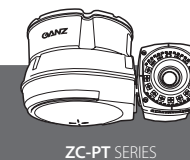

ZC-PT SERIES

C. Camera Set

CAMERA SET	
FLICKER	: OFF
SHUTT-SPD	: 1/150
APERTURE	: 10
DZOOM	: OFF
WB MODE	: AWB MODE
BLC	: OFF / ON[BLC / WDR]
D/N MODE	: AUTO
DSS MODE	: OFF
[NEXT PAGE]	
EXIT	

CAMERA SET	
HR MODE	: ON
DNR MODE	: 5
IS MODE	: OFF
[PREVIOUS PAGE]	

C-1. CAMERA SET - FLICKERLESS

The flickerless feature has options of 50Hz and 60Hz.

The default setting is OFF (NTSC : 60Hz / PAL : 50Hz).

The flickerless mode only needs to be set when there is a mismatch between the power frequency and camera sync rate. The default setting is OFF.

C-2. CAMERA SET - SHUTTER

It is for set up the Shutter Speed of camera.

• Default value is Auto and it can be changed into other one using the Joystick Left/Right of Controller.

- Change to turn : Full Auto → Manual

- Auto : Changed according to light level automatically.

- Manual : It can be changed into other one using the Focus Far Key of controller and on ON the DSS (Digital Slow Shutter), it should be set up 1/1 to 1/10,000, on OFF, 1/50(1/60)~1/10,000.

C-3. CAMERA SET - APERTURE

Aperture correction enhances the picture details and sharpness by increasing the gain of the camera.

Increase the value to sharpen the image, decrease to soften it the default setting is 10. (The aperture level is from 01 ~ 15.)

C-4. CAMERA SET - D ZOOM

Digital zoom is enabled to apply when the zoom lens has reached its maximum optical zoom in capability. The default setting is OFF.

C-5. CAMERA SET - WB MODE

White balance functions has 4 modes and may need to be changed depending on the situation.

• AWB Mode : 3,200°K to 6,500°K (Default)

• Indoor : up to 3,200°K

• Outdoor : up to 5,800°K

OSD Menu Setting



ZC-PT SERIES

C-6. CAMERA SET - BLC (Back Light Compensation)

From simple ON / OFF setting to user friendly BLC status indication [BLC] status with control of controller by "FOCUS FAR KEY" ("■" signal appeared) With the control of joystick on controller by LEFT / RIGHT, setting change of [BLC] / [WDR] is available.

Setting change completed by pressing FOCUS FAR KEY. ("■" signal disappeared.) This function can be recalled by pushing 93+Preset button.

C-7. CAMERA SET - D/N MODE

The dome camera can operate in day / night mode and will switch depending on lighting conditions. Alternatively it can be forced into color only mode.

The default setting is AUTO MODE. This function can be recalled by pushing 94+Preset button.

C-8. CAMERA SET - DSS MODE (DIGITAL SLOW SHUTTER)

If digital slow shutter is enabled the exposure time of the camera is increased, thus allowing more light to be collected and improving low light response.

This setting should not be enabled if the dome is touring at night or fast moving objects are likely to be in the scene as smearing is also increased.

The default setting is OFF.

C-9. CAMERA SET - [NEXT PAGE] - HR MODE

Images with a high resolution can be obtained using a newly developed DSP for improved pictur quality. The default setting is OFF.

• OFF : 530TV Lines

• ON : 550TV Lines

C-10. CAMERA SET - [NEXT PAGE] - DNR MOED

It enables noise reduction digitally.

It sets the noise reduction rate using LEFT / RIGHT key of CONTROLLER JOYSTICK [OFF, 1~5]. The default setting is OFF

C-11. CAMERA SET - [NEXT PAGE] - IS MODE

It help to stabilized video image when camera revealed to wind or other environmental reasons. The default setting is OFF.

OSD Menu Setting



ZC-PT SERIES

D. Preset Set

PRESET SET	
PRESET NO	: 01
PRESET ID	: PRESET 01
PAN : XXX.X	TILT : XX.X
FREEZE MODE	: OFF
FREEZE ALL	: OFF
SAVE	
EXIT	

D-1. PRESET - PRESET NO

Up to 165 preset positions are available.

Use the joystick or pan left / right keys to select the number.

D-2. PRESET - PRESET ID

To create preset titles use the joystick or pan left / light keys to navigate the menu.

The ZOOM TELE button moves to the next character from left to right and ZOOM WIDE button moves to the next character from right to left. (Space displays when □ appears.)

D-3. PRESET - PAN : XXX.X TILT : XX.X

Preset FOCUS FAR button in order to set preset position then, use the joystick or pan left / right keys to the position where memorized preset number is needed.

Then press FOCUS FAR button again after setting a preset location.

D-4. FREEZE MODE : On Preset, you make a decision whether you get it move or stop.

On ON, Freeze Preset can be working on.

D-5. FREEZE ALL : You can set it up into ON / OFF, on ON, Freeze all should be working on.

D-6. PRESET - SAVE

Move the joystick right or press the pan right key when the cursor is at SAVE and then the cursor will be located on Preset ID for the continuous preset No. setting.

D-7. PRESET - EXIT

To escape this page, move joystick to the right direction.



E. Auto Scan Set

66+Preset button is working as AUTO SCAN after setting.

AUTO SCAN SET	
START ANGLE	:XXX.X:XXX.X
END ANGLE	:XXX.X:XXX.X
DIRECTION	:CW
ENDLESS	:OFF
SPEED	:10°/S
DWELL TIME	:03
SAVE AND EXIT	
EXIT	

E-1. AUTO SCAN - START ANGLE.

To set the start position, press FOCUS FAR button then move the dome to the required start position. Press FOCUS FAR button again is to escape.

E-2. AUTO SCAN - END ANGLE

To set the end position, press FOCUS FAR button then move the dome to the required end position. Press FOCUS FAR button again is to escape.

E-3. AUTO SCAN - DIRECTION

Auto Scan directions are available as CW or CCW.

- CW : Clock wise direction. [Default]
- CCW : Count Clock Wise Direction.

E-4. AUTO SCAN - ENDLESS

Auto Scan can be set to endless rotation by enabling the endless option. The default setting is OFF.

E-5. AUTO SCAN – SPEED

The scan speed can be programmed from 05°/S up to 35°/S. The default setting is 10°/S.

E-6. AUTO SCAN - DWELL TIME

The dwell time at the start and end points can be programmed from 1 second to 30 seconds. The default setting is 03 seconds.

E-7. AUTO SCAN - SAVE AND EXIT

To save the memorized data and escape this page, move the joystick right or press the pan right key when the cursor is at SAVE AND EXIT.

E-8. AUTO SCAN - EXIT

To escape this page, move joystick to the right direction.



F. Tour Set

8 Programmable tours can be set and each tour can have up to 64 preset steps. After setting up the tours the 71 ~ 78+Preset buttons launch group tours #1 ~ 8.

TOUR SET	
TOUR NO	:01
TOUR TITLE	:TOUR 01□□□□□□□□
TOUR STEP	:01
PRESET NO	:01
DWELL TIME	:03
SPEED	:200°/S
SAVE	
EXIT	

F-1. TOUR SET - TOUR NO.

Up to 8 group tours can be programmed.

F-2. TOUR SET - TOUR TITLE

To set a tour title, use the joystick left / right or pan left / right keys.

Each title can have up to 16 characters. Press ZOOM TELE button to move the next character from left to the right and ZOOM WIDE button to move the next character from right to left. (Space displays when □ appears.) The tour title is not displayed on the monitor and is only for the reference of user.

F-3. TOUR SET - TOUR STEP

Each tour group consists of up to 60 preset steps with different dwell time and speed.

It is possible to match any preset # for any tour step.

F-4. TOUR SET- PRESET NO.

For each tour step it is possible to select any preset number up to 64. The default setting is BLK.

F-5. TOUR SET - DWELL TIME

Dwell time can be programmed from 1-99 seconds. The default setting is 03 seconds.

F-6. TOUR SET – SPEED

Each tour step can be set with a different speed up to 200°/S.

F-7. TOUR SET - SAVE

To save the memorized data and escape this page, move the joystick right or press the pan right key when cursor is at SAVE.

F-8. TOUR SET - EXIT

To escape this page, move joystick to the right direction.



G. Privacy Set

8 Privacy masking zones can be set.

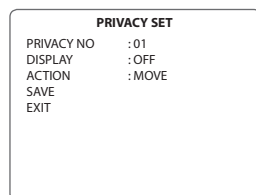

G-1. PRIVACY SET - PRIVACY NO.

Up to 8 privacy masking zones can be set.

G-2. PRIVACY SET - DISPLAY

Move the joystick right or left or press pan right / left to set ON in order to show the selectable block in the center of the monitor. This block appears as a translucent square with blue color when set ON. The default setting is OFF.

G-3. PRIVACY SET - ACTION (MOVE / ADJUST)

To set the blocking area, press FOCUS FAR button when MOVE MODE is displayed.

Then use the joystick or pan keys to the user defined area in order to set the blocking area.

Then press FOCUS FAR button again to escape from Move mode.

To adjust the size of the blocking area, move the joystick or use the pan keys when the cursor is on ACTION. After it has changed to ADJUST MODE, press FOCUS FAR button in order to adjust the size of the blocking area. The size of the blocking area can be adjusted by using joystick up / down or left / right or the pan and tilt keys.

After adjusting the size of the blocking area, press FOCUS FAR button to escape the ADJUST mode.

- ADJUST : You can change the masking size by using the joystick or pan keys.
- MOVE : You can move the masking area by using the joystick or pan keys. (Default)



G-4. PRIVACY SET - SAVE.

After setting the privacy masking zone, to save the data, move the joystick right or pan right key when the cursor is on SAVE.

After saving the data, the cursor moves to PRIVACY NO.2 automatically to prepare for the next privacy masking zone.

G-5. PRIVACY SET - EXIT

To escape this page, move the joystick right.

H. Pattern Set

8 Programmable patterns are available with 16 characters of title.

After set the data to the each pattern #1 ~ 8, 81 ~ 88+preset buttons are working as pattern #1 ~ 8.

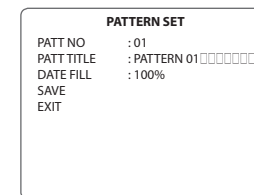

H-1. PATTERN SET - PATT NO.

Up to 8 Programmable user-defined patterns are available.

H-2. PATTERN SET - PATT TITLE.

To set PATTERN TITLE move Joystick left / right or use the pan keys.

Press ZOOM TELE button moves to the next character from the left / right and ZOOM WIDE button moves to the next character from the right / left. (Space displays when □ appears.)

The pattern title is not displayed on the monitor, but only for the reference of the user.

H-3. PATTERN SET - DATA FILL

To memorize a pattern, press FOCUS FAR button in order to start the process. The progress is shown as % filled. Press FOCUS FAR button again in order to escape.

OSD Menu Setting



ZC-PT SERIES

H-4. PATTERN SET - SAVE

To save the memorized pattern data, move the joystick right or press the pan right key when the cursor is on SAVE. Then the cursor moves to the PATT NO.02 in order to prepare for the next pattern.

H-5. PATTERN SET - EXIT

To escape this page, move the joystick right or press the pan right key.

OSD Menu Setting



ZC-PT SERIES

I. Alarm Set

4 Alarm inputs are available and each alarm is activating to presets, group tours or patterns.

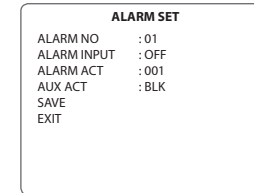

I-1. ALARM SET - ALARM NO.

Up to 4 alarms are selectable by using joystick right or pressing the pan right key when the cursor is on ALARM NO.

I-2. ALARM SET - ALARM INPUT

Alarm inputs can be programmed as NC (Normally Close) or NO (Normally Open).

The default setting is OFF.

I-3. ALARM SET - ALARM ACT

Active alarms can trigger modes such as presets, Group tours 1-8, and Patterns 1-8.

Use the joystick or pan keys to select any preset number, Group tour No.

I-4. ALARM SET - AUX ACT

You can select one of BLK (No AUX triggering) / AUX1 (triggering AUX1) / AUX2 (triggering AUX2) and default value is BLK.

If ALARM triggers AUX, AUX will be off after 5 seconds. If many ALARMS trigger AUX port one by one, the last one will be off after 5 seconds.

I-5. ALARM SET - SAVE

After setting up the alarm features, to save the data move the joystick right or press the pan right key when the cursor is on SAVE. After saving the data, the cursor moves to Alarm NO.2 automatically to prepare for the next alarm.

I-6. ALARM SET - EXIT

To escape this page, move the joystick right or press the pan right key.

- Before activating Alarms, you must set ALARM ENABLE at DOME SET ALARM ENABLE.

OSD Menu Setting



ZC-PT SERIES

J. Sector Set

Up to 8 programmable sectors are available with 16 characters.
This feature is useful to memory the certain location such as parking zone or so on.

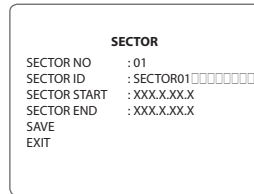

J-1. SECTOR SET - SECTOR NO.

Up to 8 programmable sectors are available.

J-2. SECTOR SET - SECTOR ID

To set a SECTOR ID, use the joystick or pan left /right keys.

Press ZOOM TELE button to move to the next character from left to right and ZOOM WIDE button to move to the next character from right to left. (Space displays when □ appears.)

J-3. SECTOR SET - SECTOR START

To set a SECTOR START position press FOCUS FAR button then move the joystick or pan keys to set the position. Press FOCUS FAR button again to escape.

J-4. SECTOR SET - SECTOR END

To set a SECTOR END position press FOCUS FAR button then move the joystick or pan keys to set the position. To press FOCUS FAR button again to escape.

J-5. SECTOR SET - SAVE

After setting the SECTOR position, to save the data move the joystick right or press the pan right key when the cursor is on SAVE. After saving the data, the cursor moves to sector No. 2 automatically to prepare for the next sector.

J-6. SECTOR SET – EXIT

To escape this page, move joystick to the right or press the pan right key.

K. Exit

To escape OSD Main Menu, move joystick to the right or left direction then this camera is ready to operate.

DIP Switch Setting

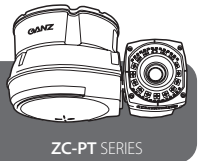

ZC-PT SERIES

A. ID Setting

The camera has camera ID to be controlled by controller or DVR.
After opening, set ID using DIP SW1.

- Factory default : Camera ID = 1

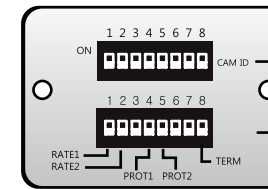

Dip switch 1
(Camera Setting)

Dip switch 2
(Termination/Baud Rate Setting)

ID	SW1-#1	SW1-#2	SW1-#3	SW1-#4	SW1-#5	SW1-#6	SW1-#7	SW1-#8
1	ON	OFF	OFF	OFF	OFF	OFF	OFF	OFF
2	OFF	ON	OFF	OFF	OFF	OFF	OFF	OFF
3	ON	ON	OFF	OFF	OFF	OFF	OFF	OFF
4	OFF	OFF	ON	OFF	OFF	OFF	OFF	OFF
5	ON	OFF	ON	OFF	OFF	OFF	OFF	OFF
6	OFF	ON	ON	OFF	OFF	OFF	OFF	OFF
7	ON	ON	ON	OFF	OFF	OFF	OFF	OFF
8	OFF	OFF	OFF	ON	OFF	OFF	OFF	OFF
9	ON	OFF	OFF	ON	OFF	OFF	OFF	OFF
10	OFF	ON	OFF	ON	OFF	OFF	OFF	OFF
11	ON	ON	OFF	ON	OFF	OFF	OFF	OFF
12	OFF	OFF	ON	ON	OFF	OFF	OFF	OFF
13	ON	OFF	ON	ON	OFF	OFF	OFF	OFF
14	OFF	ON	ON	ON	OFF	OFF	OFF	OFF
15	ON	ON	ON	ON	OFF	OFF	OFF	OFF
16	OFF	OFF	OFF	OFF	ON	OFF	OFF	OFF
17	ON	OFF	OFF	OFF	ON	OFF	OFF	OFF
18	OFF	ON	OFF	OFF	ON	OFF	OFF	OFF
19	ON	ON	OFF	OFF	ON	OFF	OFF	OFF
20	OFF	OFF	ON	OFF	ON	OFF	OFF	OFF
21	ON	OFF	ON	OFF	ON	OFF	OFF	OFF
22	OFF	ON	ON	OFF	ON	OFF	OFF	OFF
23	ON	ON	ON	OFF	ON	OFF	OFF	OFF
24	OFF	OFF	OFF	ON	ON	OFF	OFF	OFF
25	ON	OFF	OFF	ON	ON	OFF	OFF	OFF
26	OFF	ON	OFF	ON	ON	OFF	OFF	OFF
27	ON	ON	OFF	ON	ON	OFF	OFF	OFF
28	OFF	OFF	ON	ON	ON	OFF	OFF	OFF
29	ON	OFF	ON	ON	ON	OFF	OFF	OFF
30	OFF	ON	ON	ON	ON	OFF	OFF	OFF
31	ON	ON	ON	ON	ON	OFF	OFF	OFF
32	OFF	OFF	OFF	OFF	OFF	ON	OFF	OFF
33	ON	OFF	OFF	OFF	OFF	ON	OFF	OFF
34	OFF	ON	OFF	OFF	OFF	ON	OFF	OFF

DIP Switch Setting



ZC-PT SERIES

ID	SW1-#1	SW1-#2	SW1-#3	SW1-#4	SW1-#5	SW1-#6	SW1-#7	SW1-#8
35	ON	ON	OFF	OFF	OFF	ON	OFF	OFF
36	OFF	OFF	ON	OFF	OFF	ON	OFF	OFF
37	ON	OFF	ON	OFF	OFF	ON	OFF	OFF
38	OFF	ON	ON	OFF	OFF	ON	OFF	OFF
39	ON	ON	ON	OFF	OFF	ON	OFF	OFF
40	OFF	OFF	OFF	ON	OFF	ON	OFF	OFF
41	ON	OFF	OFF	ON	OFF	ON	OFF	OFF
42	OFF	ON	OFF	ON	OFF	ON	OFF	OFF
43	ON	ON	OFF	ON	OFF	ON	OFF	OFF
44	OFF	OFF	ON	ON	OFF	ON	OFF	OFF
45	ON	OFF	ON	ON	OFF	ON	OFF	OFF
46	OFF	ON	ON	ON	OFF	ON	OFF	OFF
47	ON	ON	ON	ON	OFF	ON	OFF	OFF
48	OFF	OFF	OFF	OFF	ON	ON	OFF	OFF
49	ON	OFF	OFF	OFF	ON	ON	OFF	OFF
50	OFF	ON	OFF	OFF	ON	ON	OFF	OFF
51	ON	ON	OFF	OFF	ON	ON	OFF	OFF
52	OFF	OFF	ON	OFF	ON	ON	OFF	OFF
53	ON	OFF	ON	OFF	ON	ON	OFF	OFF
54	OFF	ON	ON	OFF	ON	ON	OFF	OFF
55	ON	ON	ON	OFF	ON	ON	OFF	OFF
56	OFF	OFF	OFF	ON	ON	ON	OFF	OFF
57	ON	OFF	OFF	ON	ON	ON	OFF	OFF
58	OFF	ON	OFF	ON	ON	ON	OFF	OFF
59	ON	ON	OFF	ON	ON	ON	OFF	OFF
60	OFF	OFF	ON	ON	ON	ON	OFF	OFF
61	ON	OFF	ON	ON	ON	ON	OFF	OFF
62	OFF	ON	ON	ON	ON	ON	OFF	OFF
63	ON	ON	ON	ON	ON	ON	OFF	OFF
64	OFF	OFF	OFF	OFF	OFF	OFF	ON	OFF
65	ON	OFF	OFF	OFF	OFF	OFF	ON	OFF
66	OFF	ON	OFF	OFF	OFF	OFF	ON	OFF
67	ON	ON	OFF	OFF	OFF	OFF	ON	OFF
68	OFF	OFF	ON	OFF	OFF	OFF	ON	OFF
69	ON	OFF	ON	OFF	OFF	OFF	ON	OFF
70	OFF	ON	ON	OFF	OFF	OFF	ON	OFF
71	ON	ON	ON	OFF	OFF	OFF	ON	OFF
72	OFF	OFF	OFF	ON	OFF	OFF	ON	OFF
73	ON	OFF	OFF	ON	OFF	OFF	ON	OFF
74	OFF	ON	OFF	ON	OFF	OFF	ON	OFF
75	ON	ON	OFF	ON	OFF	OFF	ON	OFF
76	OFF	OFF	ON	ON	OFF	OFF	ON	OFF
77	ON	OFF	ON	ON	OFF	OFF	ON	OFF
78	OFF	ON	ON	ON	OFF	OFF	ON	OFF
79	ON	ON	ON	ON	OFF	OFF	ON	OFF
80	OFF	OFF	OFF	OFF	ON	OFF	ON	OFF

DIP Switch Setting

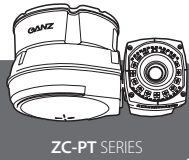

ZC-PT SERIES

ID	SW1-#1	SW1-#2	SW1-#3	SW1-#4	SW1-#5	SW1-#6	SW1-#7	SW1-#8
81	ON	OFF	OFF	OFF	ON	OFF	ON	OFF
82	OFF	ON	OFF	OFF	ON	OFF	ON	OFF
83	ON	ON	OFF	OFF	ON	OFF	ON	OFF
84	OFF	OFF	ON	OFF	ON	OFF	ON	OFF
85	ON	OFF	ON	OFF	ON	OFF	ON	OFF
86	OFF	ON	ON	OFF	ON	OFF	ON	OFF
87	ON	ON	ON	OFF	ON	OFF	ON	OFF
88	OFF	OFF	OFF	ON	ON	OFF	ON	OFF
89	ON	OFF	OFF	ON	ON	OFF	ON	OFF
90	OFF	ON	OFF	ON	ON	OFF	ON	OFF
91	ON	ON	OFF	ON	ON	OFF	ON	OFF
92	OFF	OFF	ON	ON	ON	OFF	ON	OFF
93	ON	OFF	ON	ON	ON	OFF	ON	OFF
94	OFF	ON	ON	ON	ON	OFF	ON	OFF
95	ON	ON	ON	ON	ON	OFF	ON	OFF
96	OFF	OFF	OFF	OFF	OFF	ON	ON	OFF
97	ON	OFF	OFF	OFF	OFF	ON	ON	OFF
98	OFF	ON	OFF	OFF	OFF	ON	ON	OFF
99	ON	ON	OFF	OFF	OFF	ON	ON	OFF
100	OFF	OFF	ON	OFF	OFF	ON	ON	OFF
101	ON	OFF	ON	OFF	OFF	ON	ON	OFF
102	OFF	ON	ON	OFF	OFF	ON	ON	OFF
103	ON	ON	ON	OFF	OFF	ON	ON	OFF
104	OFF	OFF	OFF	ON	OFF	ON	ON	OFF
105	ON	OFF	OFF	ON	OFF	ON	ON	OFF
106	OFF	ON	OFF	ON	OFF	ON	ON	OFF
107	ON	ON	OFF	ON	OFF	ON	ON	OFF
108	OFF	OFF	ON	ON	OFF	ON	ON	OFF
109	ON	OFF	ON	ON	OFF	ON	ON	OFF
110	OFF	ON	ON	ON	OFF	ON	ON	OFF
111	ON	ON	ON	ON	OFF	ON	ON	OFF
112	OFF	OFF	OFF	OFF	ON	ON	ON	OFF
113	ON	OFF	OFF	OFF	ON	ON	ON	OFF
114	OFF	ON	OFF	OFF	ON	ON	ON	OFF
115	ON	ON	OFF	OFF	ON	ON	ON	OFF
116	OFF	OFF	ON	OFF	ON	ON	ON	OFF
117	ON	OFF	ON	OFF	ON	ON	ON	OFF
118	OFF	ON	ON	OFF	ON	ON	ON	OFF
119	ON	ON	ON	OFF	ON	ON	ON	OFF
120	OFF	OFF	OFF	ON	ON	ON	ON	OFF
121	ON	OFF	OFF	ON	ON	ON	ON	OFF
122	OFF	ON	OFF	ON	ON	ON	ON	OFF
123	ON	ON	OFF	ON	ON	ON	ON	OFF
124	OFF	OFF	ON	ON	ON	ON	ON	OFF
125	ON	OFF	ON	ON	ON	ON	ON	OFF
126	OFF	ON	ON	ON	ON	ON	ON	OFF

DIP Switch Setting



ZC-PT SERIES

ID	SW1-#1	SW1-#2	SW1-#3	SW1-#4	SW1-#5	SW1-#6	SW1-#7	SW1-#8
127	ON	ON	ON	ON	ON	ON	ON	OFF
128	OFF	OFF	OFF	OFF	OFF	OFF	OFF	ON
129	ON	OFF	OFF	OFF	OFF	OFF	OFF	ON
130	OFF	ON	OFF	OFF	OFF	OFF	OFF	ON
131	ON	ON	OFF	OFF	OFF	OFF	OFF	ON
132	OFF	OFF	ON	OFF	OFF	OFF	OFF	ON
133	ON	OFF	ON	OFF	OFF	OFF	OFF	ON
134	OFF	ON	ON	OFF	OFF	OFF	OFF	ON
135	ON	ON	ON	OFF	OFF	OFF	OFF	ON
136	OFF	OFF	OFF	ON	OFF	OFF	OFF	ON
137	ON	OFF	OFF	ON	OFF	OFF	OFF	ON
138	OFF	ON	OFF	ON	OFF	OFF	OFF	ON
139	ON	ON	OFF	ON	OFF	OFF	OFF	ON
140	OFF	OFF	ON	ON	OFF	OFF	OFF	ON
141	ON	OFF	ON	ON	OFF	OFF	OFF	ON
142	OFF	ON	ON	ON	OFF	OFF	OFF	ON
143	ON	ON	ON	ON	OFF	OFF	OFF	ON
144	OFF	OFF	OFF	OFF	ON	OFF	OFF	ON
145	ON	OFF	OFF	OFF	ON	OFF	OFF	ON
146	OFF	ON	OFF	OFF	ON	OFF	OFF	ON
147	ON	ON	OFF	OFF	ON	OFF	OFF	ON
148	OFF	OFF	ON	OFF	ON	OFF	OFF	ON
149	ON	OFF	ON	OFF	ON	OFF	OFF	ON
150	OFF	ON	ON	OFF	ON	OFF	OFF	ON
151	ON	ON	ON	OFF	ON	OFF	OFF	ON
152	OFF	OFF	OFF	ON	ON	OFF	OFF	ON
153	ON	OFF	OFF	ON	ON	OFF	OFF	ON
154	OFF	ON	OFF	ON	ON	OFF	OFF	ON
155	ON	ON	OFF	ON	ON	OFF	OFF	ON
156	OFF	OFF	ON	ON	ON	OFF	OFF	ON
157	ON	OFF	ON	ON	ON	OFF	OFF	ON
158	OFF	ON	ON	ON	ON	OFF	OFF	ON
159	ON	ON	ON	ON	ON	OFF	OFF	ON
160	OFF	OFF	OFF	OFF	OFF	ON	OFF	ON
161	ON	OFF	OFF	OFF	OFF	ON	OFF	ON
162	OFF	ON	OFF	OFF	OFF	ON	OFF	ON
163	ON	ON	OFF	OFF	OFF	ON	OFF	ON
164	OFF	OFF	ON	OFF	OFF	ON	OFF	ON
165	ON	OFF	ON	OFF	OFF	ON	OFF	ON
166	OFF	ON	ON	OFF	OFF	ON	OFF	ON
167	ON	ON	ON	OFF	OFF	ON	OFF	ON
168	OFF	OFF	OFF	ON	OFF	ON	OFF	ON
169	ON	OFF	OFF	ON	OFF	ON	OFF	ON
170	OFF	ON	OFF	ON	OFF	ON	OFF	ON
171	ON	ON	OFF	ON	OFF	ON	OFF	ON
172	OFF	OFF	ON	ON	OFF	ON	OFF	ON

DIP Switch Setting

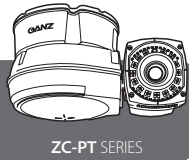

ZC-PT SERIES

ID	SW1-#1	SW1-#2	SW1-#3	SW1-#4	SW1-#5	SW1-#6	SW1-#7	SW1-#8
173	ON	OFF	ON	ON	OFF	ON	OFF	ON
174	OFF	ON	ON	ON	OFF	ON	OFF	ON
175	ON	ON	ON	ON	OFF	ON	OFF	ON
176	OFF	OFF	OFF	OFF	ON	ON	OFF	ON
177	ON	OFF	OFF	OFF	ON	ON	OFF	ON
178	OFF	ON	OFF	OFF	ON	ON	OFF	ON
179	ON	ON	OFF	OFF	ON	ON	OFF	ON
180	OFF	OFF	ON	OFF	ON	ON	OFF	ON
181	ON	OFF	ON	OFF	ON	ON	OFF	ON
182	OFF	ON	ON	OFF	ON	ON	OFF	ON
183	ON	ON	ON	OFF	ON	ON	OFF	ON
184	OFF	OFF	OFF	ON	ON	ON	OFF	ON
185	ON	OFF	OFF	ON	ON	ON	OFF	ON
186	OFF	ON	OFF	ON	ON	ON	OFF	ON
187	ON	ON	OFF	ON	ON	ON	OFF	ON
188	OFF	OFF	ON	ON	ON	ON	OFF	ON
189	ON	OFF	ON	ON	ON	ON	OFF	ON
190	OFF	ON	ON	ON	ON	ON	OFF	ON
191	ON	ON	ON	ON	ON	ON	OFF	ON
192	OFF	OFF	OFF	OFF	OFF	OFF	ON	ON
193	ON	OFF	OFF	OFF	OFF	OFF	ON	ON
194	OFF	ON	OFF	OFF	OFF	OFF	ON	ON
195	ON	ON	OFF	OFF	OFF	OFF	ON	ON
196	OFF	OFF	ON	OFF	OFF	OFF	ON	ON
197	ON	OFF	ON	OFF	OFF	OFF	ON	ON
198	OFF	ON	ON	OFF	OFF	OFF	ON	ON
199	ON	ON	ON	OFF	OFF	OFF	ON	ON
200	OFF	OFF	OFF	ON	OFF	OFF	ON	ON
201	ON	OFF	OFF	ON	OFF	OFF	ON	ON
202	OFF	ON	OFF	ON	OFF	OFF	ON	ON
203	ON	ON	OFF	ON	OFF	OFF	ON	ON
204	OFF	OFF	ON	ON	OFF	OFF	ON	ON
205	ON	OFF	ON	ON	OFF	OFF	ON	ON
206	OFF	ON	ON	ON	OFF	OFF	ON	ON
207	ON	ON	ON	ON	OFF	OFF	ON	ON
208	OFF	OFF	OFF	OFF	ON	OFF	ON	ON
209	ON	OFF	OFF	OFF	ON	OFF	ON	ON
210	OFF	ON	OFF	OFF	ON	OFF	ON	ON
211	ON	ON	OFF	OFF	ON	OFF	ON	ON
212	OFF	OFF	ON	OFF	ON	OFF	ON	ON
213	ON	OFF	ON	OFF	ON	OFF	ON	ON
214	OFF	ON	ON	OFF	ON	OFF	ON	ON
215	ON	ON	ON	OFF	ON	OFF	ON	ON
216	OFF	OFF	OFF	ON	ON	OFF	ON	ON
217	ON	OFF	OFF	ON	ON	OFF	ON	ON
218	OFF	ON	OFF	ON	ON	OFF	ON	ON



DIP Switch Setting

ZC-PT SERIES

ID	SW1-#1	SW1-#2	SW1-#3	SW1-#4	SW1-#5	SW1-#6	SW1-#7	SW1-#8
219	ON	ON	OFF	ON	ON	OFF	ON	ON
220	OFF	OFF	ON	ON	ON	OFF	ON	ON
221	ON	OFF	ON	ON	ON	OFF	ON	ON
222	OFF	ON	ON	ON	ON	OFF	ON	ON
223	ON	ON	ON	ON	ON	OFF	ON	ON
224	OFF	OFF	OFF	OFF	OFF	ON	ON	ON
225	ON	OFF	OFF	OFF	OFF	ON	ON	ON
226	OFF	ON	OFF	OFF	OFF	ON	ON	ON
227	ON	ON	OFF	OFF	OFF	ON	ON	ON
228	OFF	OFF	ON	OFF	OFF	ON	ON	ON
229	ON	OFF	ON	OFF	OFF	ON	ON	ON
230	OFF	ON	ON	OFF	OFF	ON	ON	ON
231	ON	ON	ON	OFF	OFF	ON	ON	ON
232	OFF	OFF	OFF	ON	OFF	ON	ON	ON
233	ON	OFF	OFF	ON	OFF	ON	ON	ON
234	OFF	ON	OFF	ON	OFF	ON	ON	ON
235	ON	ON	OFF	ON	OFF	ON	ON	ON
236	OFF	OFF	ON	ON	OFF	ON	ON	ON
237	ON	OFF	ON	ON	OFF	ON	ON	ON
238	OFF	ON	ON	ON	OFF	ON	ON	ON
239	ON	ON	ON	ON	OFF	ON	ON	ON
240	OFF	OFF	OFF	OFF	ON	ON	ON	ON
241	ON	OFF	OFF	OFF	ON	ON	ON	ON
242	OFF	ON	OFF	OFF	ON	ON	ON	ON
243	ON	ON	OFF	OFF	ON	ON	ON	ON
244	OFF	OFF	ON	OFF	ON	ON	ON	ON
245	ON	OFF	ON	OFF	ON	ON	ON	ON
246	OFF	ON	ON	OFF	ON	ON	ON	ON
247	ON	ON	ON	OFF	ON	ON	ON	ON
248	OFF	OFF	OFF	ON	ON	ON	ON	ON
249	ON	OFF	OFF	ON	ON	ON	ON	ON
250	OFF	ON	OFF	ON	ON	ON	ON	ON
251	ON	ON	OFF	ON	ON	ON	ON	ON
252	OFF	OFF	ON	ON	ON	ON	ON	ON
253	ON	OFF	ON	ON	ON	ON	ON	ON
254	OFF	ON	ON	ON	ON	ON	ON	ON
255	ON	ON	ON	ON	ON	ON	ON	ON



DIP Switch Setting

ZC-PT SERIES

B. 485 Termination

The 8th of DIP SW2 is used for 100Ω termination.
Set ON DIP SW2-1st of only the last looped camera from the controller.

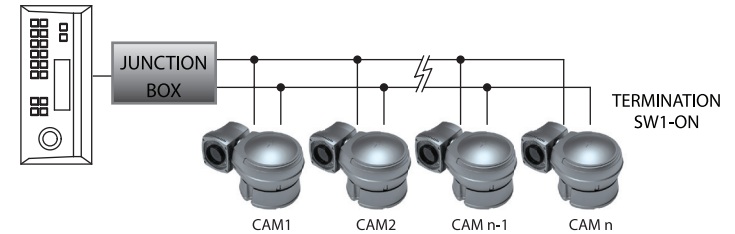

C. Protocol

The 4th, 5th of DIP SW2 above are used for protocol setting.

- Factory default : Pelco-D or Pelco-P (Auto detection)

D. Baud Rate Setting

DIP SW2 - 4th, 5th

DIP SW2 - 4 th	DIP SW2 - 5 th	BAUD RATE
OFF	ON	Pelco-D or Pelco-P
OFF	OFF	Not used
ON	ON	Not used
ON	OFF	Not used

The 7th, 8th SW of DIP SW2 above a used for BAUD RATE setting.
DIP SW can be changeable to 4,800bps, 9,600bps.

- Factory default : 2,400bps

DIP SW2 - 1 st	DIP SW2 - 2 nd	BAUD RATE
OFF	OFF	2,400bps
ON	OFF	4,800bps
OFF	ON	9,600bps
ON	ON	Not used

- The 3th, 6th, 7th of DIP SW2 are not used.

Trouble Shooting



ZC-PT SERIES

If you have trouble operating in your camera, refer to the following.

Problem	Solution
NO OPERATION	<ul style="list-style-type: none"> • Check if the power supply is AC 24V. • Check if RS-485 communication cable is connected correctly. • Check camera ID setting. • Check the termination.
NO PICTURE	<ul style="list-style-type: none"> • Check if all the cables are connected correctly. • Check the monitor is adjusted correctly. • Check if video signal line is cut.
DARK SCREEN	<ul style="list-style-type: none"> • Adjust the monitor status.
ABNOMAL CAMERA OPERATION STATUS	<ul style="list-style-type: none"> • Check if the voltage level is out of the specification. • Check the termination.
SCREEN NOT CLEAR	<ul style="list-style-type: none"> • Check if there is dust on a lens. • Adjust the monitor status. • If excessive light is seen on a screen, change the camera angle or location. • Adjust the lens focus again.

Specification

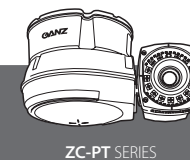

ZC-PT SERIES

Model	ZC-PT336N/P-IR
PAN/TILT	
Pan Rotation Angle	0° ~ 360°Endless
Pan Speed	Manual : 0.1~200°/sec (64step), Preset : MAX 300°/sec
Tilt Rotation Angle	0° ~ 360°Endless
Tilt Speed	Manual : 0.1~200°/sec (64step), Preset : MAX 300°/sec
System Accuracy	0.009°
FUNCTION	
Preset	165 Positions (Freeze Preset and AF / MF Preset available)
Group Tour	Max. 8 Programmable group tour (each one consisting of up to 60 preset steps with different steps)
Auto Scan	Programmable Auto Scan
Pattern	8 Programmable Patterns (total 480 seconds)
Sector	8 Selectable Sectors with 16 characters
Home Position (Recover)	Yes (Auto(recover) / Preset / Tour / Pattern / Scan / OFF)
Password Protection	Yes
Privacy Zone	8
Image Stabilizer	Yes
Recover Origin	Yes
WDR	Yes
SSNR	No
SSDR	No
DNR	Yes
DSS	On / Off
BLC	On / Off
HLC	No
Day & Night	Auto / Day / Night
Shutter Speed	AUTO / 1/1 ~ 1/25(DSS ON), 1/50 ~ 1/10000
Flickerless	On / Off
Alarm Input	4 alarms (with various programmable states)
Alarm Actions	Activate preset, Group Tour, Pattern or Relay output per alarm input
Aux Output	2 Relay
Auto Flip	Yes (Digital Flip)
OSD Menu	Yes
Communication	RS - 485
Protocol	Pelco D/P
IR MODE	Visual Distance : 50m
POWER	
Power Consumption	AC 24V 1.6A 39W MAX
Power Supply	AC 24V 50 / 60Hz 2.5A
OTHERS	
Construction	Aluminum die casting
Motor Type	Stepping motor (2 Phase)
Micro Steps	1/16 Micro Step
Storage Temperature	-20°C ~ 60°C (-4°F ~ 140°F)
Operating Temperature	-30°C ~ 50°C (-40°F ~ 122°F) 100% humidity. The first start-up camera from storage condition over 0°C (32°F)(No Heater)
Certifications	CE, FCC, IP68
CAMERA MODULE	
Image Sensor	1/4" Sony Exview HAD CCD
Total Image Pixels	NTSC : 811(H) x 508(V) 410K / PAL : 795(H) x 596(V) 470K
Horizontal Resolution	550TVL
Lens	36x F=1.6~4.5, f=3.4~122.4mm (Digital : 12X / Total : 432X)
Min. Illumination	1.4 Lux(DSS OFF) 0.1Lux(Color : 50IRE) 0.01Lux(B/W : ICR ON)
Luminance S/N Ratio	More than 50dB
Video Output	Composite video output 75Ω Terminated

Dimension

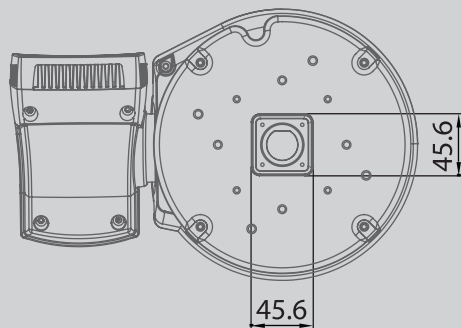
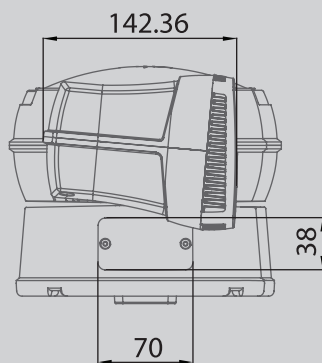
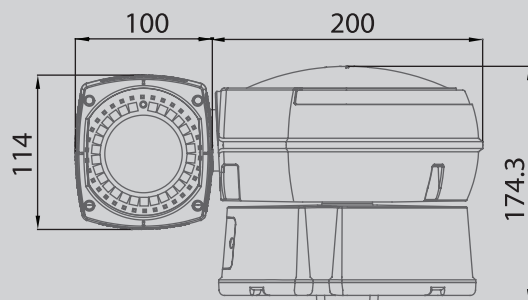
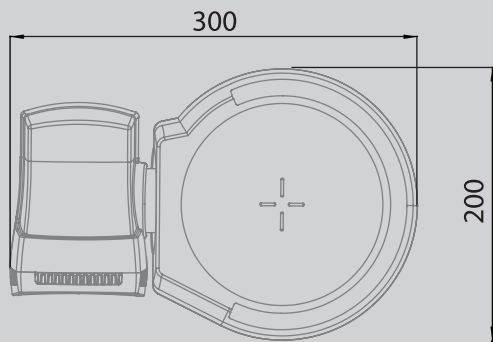

UNITS : mm

Memo

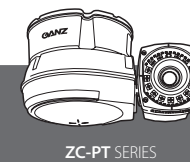

Memo

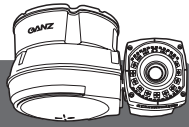

ZC-PT SERIES

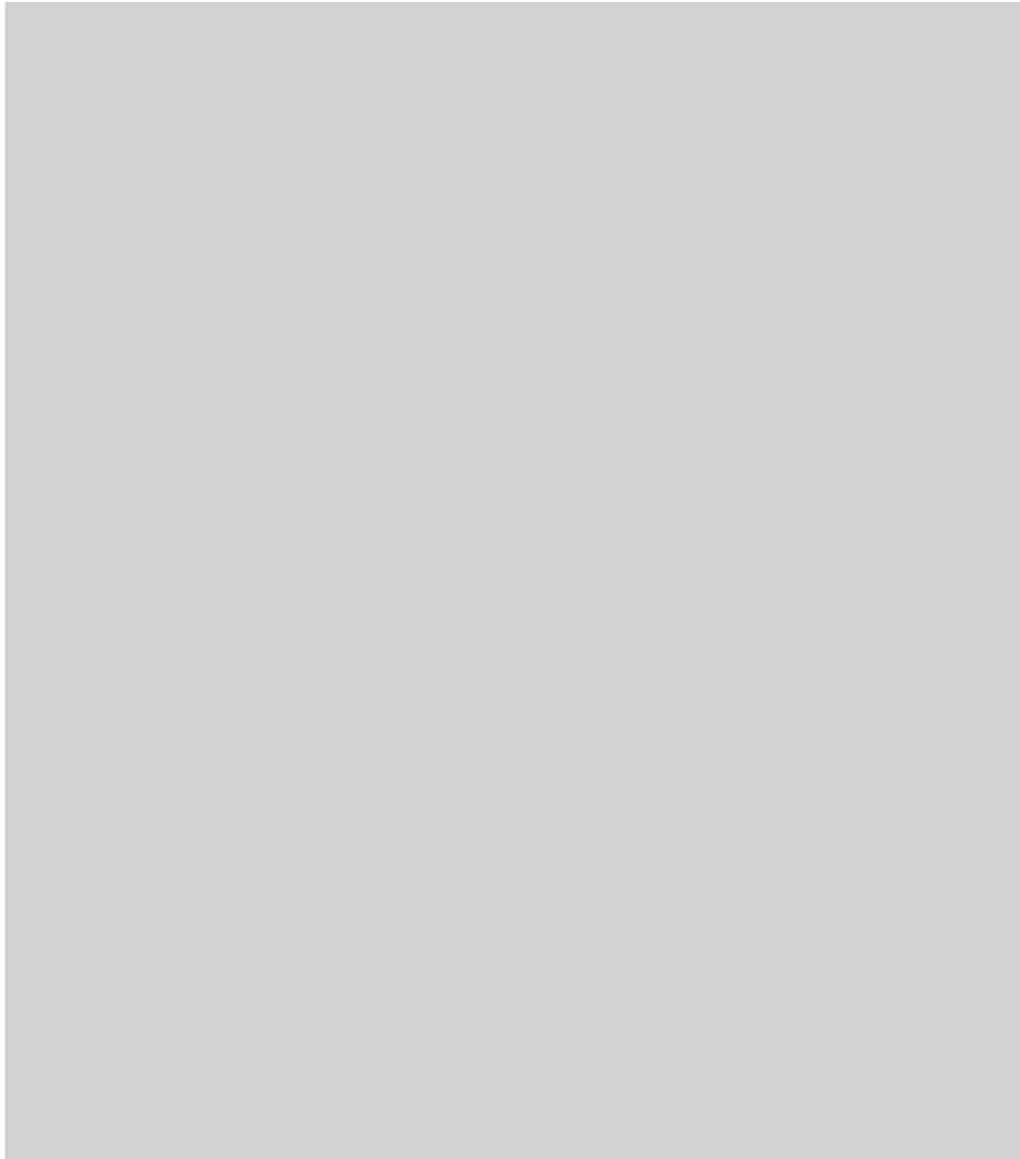

Memo



ZC-PT SERIES

